



G200 Analyser Range

Operating Manual

G200 N₂O 0-1,000ppm

G210 N₂O 0-100%

Geotechnical Instruments (UK) Ltd

Sovereign House

Queensway

Leamington Spa

Warwickshire

CV31 3JR

England

Tel: +44 (0)1926 338111

Fax: +44 (0)1926 338110

Email: sales@geotech.co.uk

Website: www.geotech.co.uk

This page is intentionally left blank

Table of Contents

1.0	MANUAL GUIDELINES	5
1.1	Document History	5
1.2	Safety Related Information	5
1.3	Notes	5
2.0	INTRODUCTION	6
2.1	The G200 Analyser	6
2.2	The G210 Analyser	7
2.3	Instrument Components - Standard Product	8
3.0	G200 RANGE OPTIONAL PRODUCTS AND ACCESSORIES	9
3.1	Optional Products	9
3.1.1	Analyser Data Manager (Optional)	9
3.1.1.1	Event Log	9
3.1.2	Carbon Monoxide Reading (Optional – Enhancement for G210 ONLY)	9
3.1.3	Oxygen Reading (Optional – Enhancement for G210 ONLY)	9
3.1.4	Pressure Regulator Kit (Optional - G210 ONLY)	9
3.1.5	Soda Lime CO ₂ Filter	10
3.2	Instrument Accessory Products	11
4.0	INSTRUMENT FEATURES.....	12
4.1	Physical Characteristics of the Instrument Panel	12
4.2	Panel Key Functions.....	13
4.3	Instrument Connection Points	14
5.0	GENERAL OPERATIONAL INSTRUCTIONS.....	15
5.1	Switching the Instrument On	15
5.2	Switching the Instrument Off	15
5.3	Entering Data	15
5.4	Instrument Status Icons.....	16
5.5	Changing Between Parameters	17
5.6	Memory.....	17
5.7	Storage.....	17
5.8	Warning and Error Codes.....	17
5.9	Battery/Charging.....	17
5.10	Instrument Main Read Screen	18
5.10.1	Alternative Reading Methods	18
5.11	Enter ID Codes.....	19
5.12	Main Menu	20
5.12.1	Information	20
5.12.2	Utilities	21
5.12.2.1	Time & Date	21
5.12.2.2	Contrast.....	22
5.12.2.3	Alarms.....	22
5.12.2.4	Settings	23
5.12.2.5	Flow Fail	24
5.12.2.6	Logging.....	26
5.12.2.7	Reset.....	26
5.12.3	Calibration	27
5.12.4	View Data	27
5.12.4.1	Delete All	28
5.12.4.2	Filter	28
5.12.4.3	Goto.....	29

5.12.5	Diagnostics	29
5.12.6	Monitor (G200 ONLY)	29
5.13	TWA and Average Calculations in ADM	31
6.0	TAKING READINGS.....	33
6.1	Preliminary Checks - Best Practice	33
6.2	G200 Gas Measurement Process – Best Practice	34
6.3	G210 Gas Measurement Process – Best Practice	35
7.0	CALIBRATION.....	36
7.1	User Calibration	36
7.2	Calibration Gases	36
7.3	Calibration Set-up	36
7.4	Calibration Equipment.....	37
7.5	Calibration Method	37
7.5.1	Zero Calibration.....	38
7.5.2	Span Channels	38
7.5.3	Reset Factory Settings.....	39
7.6	Last Field Calibration	39
7.7	Calibration Record	39
7.8	Recommended Gases for Calibration.....	40
7.9	G200 Range Calibration – Best Practice.....	41
8.0	PROBLEM SOLVING.....	42
8.1	Warnings and Errors	42
8.2	Battery No Charge Reset	42
8.3	Self-test Warning Messages	43
8.4	User Calibration Trouble Shooting.....	45
8.5	Cross-Gas Effects	46
8.6	Hardware Reset.....	47
9.0	SERVICE.....	48
10.0	WARRANTY POLICY	49
11.0	EVENT LOG	50
12.0	CERTIFICATE OF CALIBRATION	52
13.0	IMPORTANT NOTICE TO ALL CUSTOMERS.....	53
14.0	EC DECLARATION OF CONFORMITY	54
15.0	GLOSSARY OF TERMS	55

1.0 Manual Guidelines

1.1 Document History

Issued By	Issue Date	Change Control ID	Issue No.	Reason for Change
CAM	March 2014	CR898	1.28	Updated battery performance and charge times in section 5.9
		CR642		Updated hardware reset in section 8.6
				Updated calibration section.

1.2 Safety Related Information

Information in this manual that may affect the safety of users and others is preceded by the following symbol:

 **Warning**

Failure to follow this information may result in physical injury which in some cases could be fatal.

1.3 Notes

Important/useful information and instructions are shown clearly throughout the manual in a note format.

For example:

- ✍ Note: For further information, please contact Sales at Geotechnical Instruments (UK) Limited on +44(0)1926 338111 or email Sales@geotech.co.uk.

2.0 Introduction

This manual explains how to use the instrument model types listed below:

- G200 N₂O 0-1,000ppm (plus 10,000 range low resolution)
- G210 N₂O 0-100%+CO₂ 0-2,000ppm+O₂ 0-100%+CO 0-500ppm

The G200 analyser is specifically designed to safety check background levels of N₂O (0-1,000ppm) in medical applications. The G210 analyser is specifically designed for highly accurate measurement and verification of the quality of piped medical gases in hospitals. Both units have been developed to incorporate the latest technology and specification requirements, which provide the user with a fast, simple-to-use and accurate piece of monitoring instrumentation.

✍ Note: These instruments are sensitive pieces of scientific equipment, and should be treated as such.

 Warning	If the equipment is used in a manner not specified by the manufacturer, the protection provided by the equipment may be impaired.
--	---

2.1 The G200 Analyser



The G200 analyser is specifically designed to safety check background zone levels of N₂O (0-1,000ppm) in medical applications. This instrument measures the long term exposure to N₂O gas along with the TWA (time weighted average), leak detection for N₂O storage. It is a dual purpose background analyser or personal analyser and is highly portable.

The G200 analyser has the following features:

- O₂, N₂O 0-1,000ppm
- Data storage for 1,000 readings and download

- EH40 occupational exposure limits calculated (TWA) – applicable to the UK only
- Leak detection
- User settable alarms
- Data download for graphing and reporting
- Four modes of operation: personal safety - TWA 8 hour read back; room monitor – background levels, user defined times; leak mode – 1-10,000ppm fast response; and standard measuring.

2.2 The G210 Analyser



The G210 analyser is specifically designed for highly accurate measurement and verification of the quality of piped N₂O and O₂ gases in hospitals. This instrument enables up to four gases to be measured, easy user calibration, quick verification of gas quality, user maintained site and sample point IDs for monitoring as well as identification of contaminants CO and CO₂.

The analyser has the following features:

- N₂O 0-100%
- O₂ 0-100% (optional)
- CO 0-500ppm (optional)
- CO₂ 0-2,000ppm
- Data storage with site and ID input
- Data download for graphing and reporting

2.3 Instrument Components - Standard Product**G200 Model****Reference:**

- A Analyser
- B Mains Battery Charger
- C Mains Battery Charger Adaptors:
Europe
US
Australia
- D Soda Lime CO₂ Filter (G200 Only)
- E Operating Manual

3.0 G200 Range Optional Products and Accessories

3.1 Optional Products

The G200 analyser range has a number of optional products for purchase which enhance the usability and enable further analysis of data and reading information.

✍ Note: For more information on the features listed in this section please contact Sales at Geotech (UK) Limited on +44(0)1926 338111 or email Sales@geotech.co.uk.

3.1.1 Analyser Data Manager (Optional)

Analyser Data Manager software application enables the operator to maximise the operation of the analyser by providing the ability to:

- Obtain instrument status.
- View the instrument readings and event log data.
- Download and store readings for further analysis.
- Graph downloaded instrument readings.
- View, import and export the instrument configuration.
- Update the instrument's firmware.
- Copy data from the G200 Client into other packages such as MS Excel.
- Email data directly from the application.
- Configure remote access to a central database.
- Print graph and tabular data.

3.1.1.1 Event Log

The G200 range of instruments incorporates the facility to log significant events via the 'Event Log'. This can be used as an aid to monitoring the use of the instrument. It can also be used as a diagnostic tool if there is a problem with the instrument.

The event log can only be viewed via the optional Analyser Data Manager software. It cannot be viewed on the analyser screen. Applicable events are stored in the event log automatically. No user intervention is required.

The event log can hold approximately 270 events. If the log becomes full then it begins to overwrite the older events. This can be identified by the index field which starts from event number 1. The log is cleared when the instrument is reset.

✍ Note: Please refer to section '12.0 Event Log' of this operating manual for further information.

3.1.2 Carbon Monoxide Reading (Optional – Enhancement for G210 ONLY)

The G210 instrument has the optional facility to use an internal CO cell (specified at the time of manufacture or upon request at service interval). This allows the instrument to read and display carbon monoxide readings along with N₂O.

3.1.3 Oxygen Reading (Optional – Enhancement for G210 ONLY)

The G210 instrument has the optional facility to use an internal oxygen cell (specified at the time of manufacture or upon request at service interval). This allows the instrument to read and display oxygen readings along with N₂O, CO₂, CO.

3.1.4 Pressure Regulator Kit (Optional - G210 ONLY)

A pressure regulator kit must be used when taking gas readings to restrict the flow into the instrument when using the G210 analyser. When sampling piped medical gases the pressure of the gas needs to be reduced before it is passed to the instrument. This

reduces the pressure to 100mbar suitable for the instrument. It is recommended that the operator uses the pressure regulator kit purchased separately from Geotech (UK) Limited.

✍ Note: Alternative methods of pressure reduction are available and could be used. However, to avoid irreversible damage to the instrument, please seek guidance from the supplier / manufacturer before using any other pressure device.

⚠ Warning	Do NOT use the instrument at full piped pressure (maximum pressure 300mbar).
------------------	--

3.1.5 Soda Lime CO₂ Filter

The G200 instrument must only be used with a soda lime CO₂ filter attached. The filter removes CO₂ if present when a reading is taken.

This filter should always be fitted when using a G200 instrument as any CO₂ will cross-contaminate the N₂O reading. For further information please refer to section '8.5 – Cross Gas Effects'.

The life of the filter will vary depending on usage. The crystals change colour from pale green-blue to white-grey. The filter element should be discarded when a significant percentage of the crystals start to turn a white-grey colour see below:-

New Filter (Pale Green-Blue)



Used Filter (White-Grey)



Assemble Filter and Connect to Instrument as Shown

The filters are supplied in a sealed storage bag to improve their shelf life. The parts supplied should be assembled as per the diagram shown.

✍ Note: A soda lime CO₂ filter can also be used to zero other G Range instruments.



3.2 Instrument Accessory Products

Optional accessory and replacement parts may be purchased for the G200 range from Geotechnical Instruments (UK) Limited direct. Please refer to the website www.geotech.co.uk for further details on pricing and how to order.



Ref	Description	Mfr Order Code
A	USB Lead	USBLEAD2
B	Spare Sample Filters (pack of 5)	068296/S
C	Sample Tube Kit	G1.6
D	Hard Carry Case	050227
E	Spare Calibration Gas (Various gas options available)	CDA7.6
F	Mains Charger including Worldwide Adaptors	073024
G	Soft Carry Case	G1.11
H	Soda Lime Filter Kit	G1.10
I	Analyser Data Manager Software	G1.4
J	Pressure Regulator Kit	G1.16
K	Regulator and Tubing for Calibration Gas	G1.1

4.0 Instrument Features

4.1 Physical Characteristics of the Instrument Panel

Front View:



Reference:

- A Main Read Screen
- B Soft-Keys
- C On/Off Key
- D Pump Key
- E Key 4 – Scroll Left
- F Key 8 – Scroll Down
- G Menu Key
- H Enter Key
- I Key 2 – Scroll Up
- J Key 6 – Scroll Right

Back View:



Reference:

- L Serial Number
- M Instrument Stand

4.2 Panel Key Functions

Key	Description	Function
A	Main Read Screen	Where gas readings are displayed.
B	Soft-Keys	The function of the three 'soft-keys' on the front of the instrument panel is determined by menu options taken. Functions vary dependant upon analyser model and from screen to screen.
C	On/Off Key	Press the 'On/Off' key briefly to switch the instrument on and off.
D	Pump Key	Press the 'Pump' key to start or stop the pump.
E	Scroll Left Key	Also 'Key 4'. Enables the operator to scroll left to display more information.
F	Scroll Down Key	Also 'Key 8'. Enables the operator to scroll down to display more information.
G	Menu Key	Press the 'Menu' key to go to the 'Main' menu. Enables the operator to preset values and settings. Select options from the 'Main' menu to also view data and readings stored or held.
H	Enter Key	The 'Enter' key accepts/confirms choices made by the operator to various functions and operations. Also required to confirm numeric data entry.
I	Scroll Up Key	Also 'Key 2'. Press scroll up to view further information on the instrument read screen.
J	Scroll Right Key	Also 'Key 6'. Press scroll right to view further information on the instrument read screen.

Front Panel:

Back Panel:

L	Serial Number	Unique identification for the instrument. Verification of the serial number will be required if Technical Support assistance is needed.
M	Instrument Stand	Instrument stand.

4.3 Instrument Connection Points

Top View:

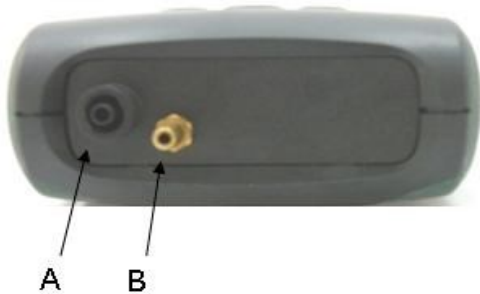

Side View:



Top View:

A Gas Inlet

Gas inlet point used to attach the sample tube and sample filter in order to take the gas reading.

B Gas Outlet

Gas outlet port used to exhaust the gas.

Side View:

C USB Cable Attachment Point

Used to connect the analyser to a PC via a USB cable in order to download data.

D Mains Battery Charger Point

Used to attach the mains charger to the analyser for charging.

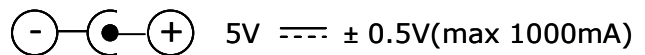

5.0 General Operational Instructions

5.1 Switching the Instrument On

- 1) To switch on the instrument, press the 'On/Off' key briefly. There will be a short beep and a slight pause followed by the Geotech logo.
- 2) The power on self-test will commence.
- 3) Assuming there are no warnings to display the instrument will continue to the 'Main Read Screen'.

5.2 Switching the Instrument Off

- 1) Purge with fresh air. Run the pump for approximately 30 seconds or until the readings have returned to normal levels.

✍ Note: Before the instrument is switched off a clean air purge should be performed. This ensures that the instrument is free from gas and ready for the next measurement. This final purge is especially important for the oxygen sensor as it may degrade if stored when contaminated with gas.

- 2) To switch off the instrument, press the 'On/Off' key briefly.

✍ Note: If the 'Auto Off' utilities setting is set to 'Yes', the analyser will switch off automatically after ten minutes if not in use.

5.3 Entering Data

During normal operation the user may be prompted to enter data or information via the keypad, i.e. entering an ID code or setting an alarm level.

When entering data into the instrument all fields are fixed format and are populated from the right.

Numeric Data:

To enter a new time 09:25:00 the user would type in 092500 using the numeric keypad in the following sequence:-

```
* __:__:0
* __:__:09
* __:0:92
* __:09:25
* _0:92:50
* 09:25:00
```

Press the 'Enter' key to confirm/accept data keyed.

Any mistakes can be corrected using the soft-key 'Delete' which will delete the last digit typed. Alternatively, the sequence can be retyped before the 'Enter' key is pressed and the existing numbers will be pushed off the screen.

Alpha-numeric Data:

When entering site IDs, alpha-numeric codes may be specified. To enter characters select either '1-Site' or '2-ID' followed by the 'Menu' key and the following screen is displayed:



Enter Site

The operator can choose upper and lowercase characters. Press the 'Menu' key again to choose lowercase characters. Use the numeric keypad on the instrument to select the appropriate letter, i.e. to select A 'Key 2', to select B 'Key 2' twice (just like on a mobile phone).

⚠ Note: The instrument will not allow invalid data to be entered; this should be deleted and re-entered.

5.4 Instrument Status Icons

The following icons may be displayed on the instrument read screens:

Icon	Description
■ ■ ■ ■ ■ □	Battery charge state
□ (flashing)	< 1 hour remaining (backlight flashes when power low)
⚡ (flashing)	Battery charging
⚡	Charged
⚙	Pump running
⚙ (flashing)	Pump stalled (Backlight turns red)
🔔	Alarm set
🔔 (flashing)	Alarm active (Backlight turns red)
🔌	USB connected to PC (flickers when transferring data)
📄	Logging mode active (flashes when memory nearly full)
🌡	Temperature probe(s) connected
💧	Humidity probe connected
📅 (flashing)	Service due (every 12 months)
📅	Service overdue
🔧	Fault/repair
⌚	Waiting

✎ Note: A red backlight is displayed if the pump is stalled or the alarm is activated. For further information, please refer to section '5.12.2.3 Alarms' or section '5.12.2.5 Flow Fail'.

5.5 Changing Between Parameters

By default, the instrument displays the 'Main Read Screen' (for gas measurement). The instrument will return to this screen after power on or when returning from the menus. The 'Scroll' keys can be used to switch to another measurement screen. Continue to press the 'Scroll' keys to return to the 'Main Read Screen'.

5.6 Memory

The memory should not be used as a permanent storage medium and any important data should be transferred to a more permanent storage medium as soon as possible. The instrument should not be stored for prolonged periods with valuable data in its memory.

5.7 Storage

When not in use the instrument should be kept in a clean, dry and warm environment, such as an office. It should be stored flat with the stand folded away which helps prolong the life of the O₂ cell.

5.8 Warning and Error Codes

When switched on the instrument will perform a predetermined self-test sequence taking approximately ten seconds. During this time many of the instrument's working parameters and settings are checked. If any operational parameters are out of specification or if the pre-programmed recommended calibration/service date has passed, errors or warnings may be displayed.

✎ Note: For further information please refer to section '8.0 Problem Solving'.

5.9 Battery/Charging

The battery used in the instrument is a 2.6 Ah Lithium-Ion cell. The instrument must be charged using the power supply supplied with your instrument. The power supply supplied is intended for indoor use only. Please ensure adequate ventilation whilst charging.

✎ Note: The instrument cannot be powered or charged via the USB connector.

When plugged into the power supply the instrument will power on and display charging. When complete the display will change to show that the instrument is charged. To switch the instrument ON whilst charging or charged is displayed, the operator will need to press and hold the power key briefly.

✎ Note: Once the instrument is fully charged, the power supply should be disconnected from the instrument.

Instrument: Input 5VDC ± 0.5V(max 1000mA)

Power Supply: Input 100 – 240V ~ 60/50 Hz 120mA

Output 5V  1000mA 5VA



✎ Note: A full charge will take approximately **4 hours**. Typically, a fully charged battery will last 10-12 hours.

When the instrument is already powered on, the operation is slightly different as the battery icon changes to a flashing plug symbol. This will stop flashing when the charge is complete.

5.10 Instrument Main Read Screen

After the analyser has been switched on and the warm-up self-tests completed the analyser will display the following screen.

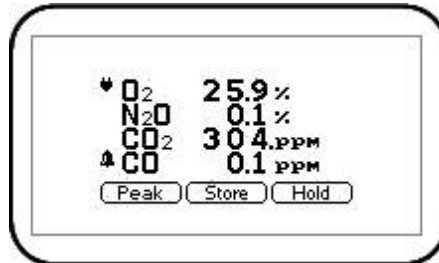

Main Read Screen

Soft-Keys:

Peak - Enables the operator to display the peak reading.

Store - Enables the operator to store the reading for viewing/download later.

Hold - Enables the operator to hold the current reading being taken.

5.10.1 Alternative Reading Methods

The G210 has three reading types or methods which each require slightly different operating procedures:

- Peak reading
- Store reading
- Hold reading

Peak Reading:

The operator can toggle the reading mode between normal (current) and peak readings. Whilst in peak reading mode the instrument will only display peak values for each of the channels. These values can then be stored by pressing the 'Store' key or automatically at the appropriate logging interval (if logging is enabled).

The peak value is reset after a reading is stored or by exiting the peak mode using the appropriate soft-key. The current mode of operation can be identified by the status of the soft-key, either 'Normal' or 'Inverse', where inverse indicates peak mode is active.

Store Reading:

The 'Store' reading option allows the operator to store the current reading. Upon selecting this option the operator is then prompted to enter or select a 'Site ID' and 'Sample Point ID' to identify the reading. Select the 'Accept' button to confirm the ID choices. For further information please refer to section '5.11 Enter ID Codes'.

Hold Reading:

The 'Hold' reading option allows the operator to freeze the currently displayed reading.

This allows it to be manually recorded or moved away from the sample point. Once activated, press the soft-key 'Hold' and the readings are fixed until the 'Hold' key is pressed again or the reading is stored.

The current mode of operation can be identified by the status of the soft-key which is inverted whilst in the hold phase.

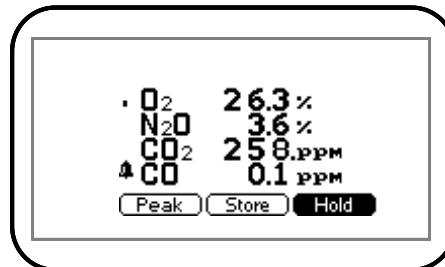

Hold Reading

Logged Reading:

Logged readings need to be configured and initiated via the 'Utilities' menu by pressing 'Key 6 - Logging'. During configuration the user will be asked to supply an ID, reading interval and pump run-time.

These parameters are used to control the reading frequency in logging mode. Once logging mode is activated the instrument will automatically record a reading at every interval until stopped by the operator or the memory becomes full. Logging is also suspended temporarily whilst the user is accessing the menu options.

Whilst the logging mode is active both the 'Pump' and 'Store' key will be deactivated; only logged readings can be stored.

5.11 Enter ID Codes

ID codes are either created at the time of selection on the analyser or created using the Analyser Data Manager software and uploaded to the instrument for selection prior to readings being taken.

The 'Site' (top level ID) and 'ID' (second level ID) fields refer to the identifier that the operator gives to a reading set before it is stored. The G200 and G210 allows the operator to enter up to 16 alpha-numeric characters which are split into two parts (to help manage the data) called 'Site' and 'ID' by default. These are entered as two sets of eight alpha-numeric identifiers by the operator (i.e. typed in). For example, the first part called 'Site' can be used to store the name of the building i.e. 'Warwick' and the second part called 'ID' could be used for location or room where the reading was taken, i.e. 'A&E1'.

It is possible using Analyser Data Manager to change the name of these fields as displayed on the instrument from 'Site' and 'ID' to something else up to seven characters, i.e. 'ward' and 'bed', depending on the application or typical mode of operation.



Enter Site ID

Soft-Keys:

- Delete - Enables the operator to backspace delete digits keyed in the 'Enter Site' field.
- Find - Enables the operator to search and find pre-stored IDs.
- Exit - Enables the operator to exit the 'Enter Site ID' screen and return to the 'Main Read Screen'.

5.12 Main Menu

The 'Main Menu' enables the operator to select options to set up specific parameters and perform operational tasks prior to sample readings being taken or to view data and information stored in the instrument.

✍ Note: Unless otherwise stated the functions and menus are the same for both the G200 and G210 instrument.

- 1) Press the 'Menu' key on the front of the instrument panel and the following screen is displayed:

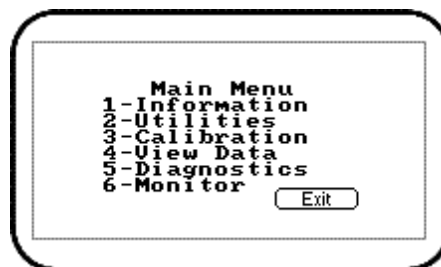

Main Menu

- 2) Press the soft-key 'Exit' to exit the 'Main' menu.

5.12.1 Information

The 'Information' option enables the operator to display information such as instrument type, serial number, current software version, service due date and the dates of the last factory and user calibrations.

- 1) From the 'Main Read Screen' press the 'Menu' key on the instrument panel.
- 2) Press 'Key 1' to display general information about the instrument.

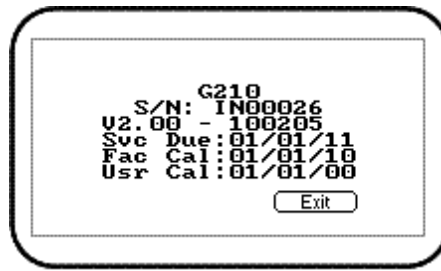

Information Screen

5.12.2 Utilities

The 'Utilities' option enables the operator to configure instrument settings prior to taking readings.

- 1) From the 'Main Read Screen' press the 'Menu' key on the instrument panel.
- 2) Press 'Key 2' to display the 'Utilities' menu and the following screen is displayed:

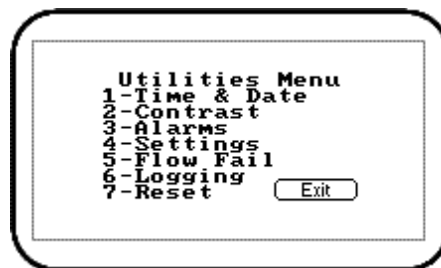

G210 Utilities Menu

5.12.2.1 Time & Date

The 'Time & Date' option enables the operator to check or set the instrument's internal clock. The current time/date are appended to every stored reading.

- 1) From the 'Main Read Screen' press the 'Menu' key on the instrument panel.
- 2) Press 'Key 2' to display the 'Utilities' menu.
- 3) Press 'Key 1' and the 'Set Time & Date' menu is displayed:

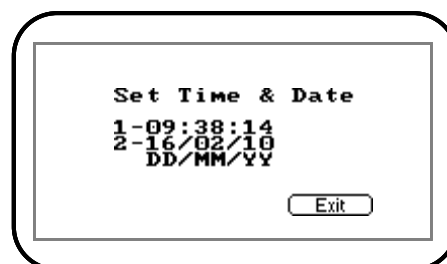

Set Time & Date

- 4) Press 'Key 1' to change the time or press 'Key 2' to change the date. Type the time or date using the numeric keypad followed by the 'Enter' key. The instrument

will not allow invalid times or dates to be entered.

✍ Note: The clock will need to be manually adjusted to cope with daylight saving changes or changes when crossing time zones.

5.12.2.2 Contrast

The 'Contrast' option enables the operator to adjust the instrument screen contrast to compensate for changes in ambient temperature. The default setting is 0.

- 1) From the 'Main Read Screen' press the 'Menu' key on the instrument panel.
- 2) Press 'Key 2' to display the 'Utilities' menu.
- 3) Press 'Key 2' to select the instrument panel contrast settings and the following screen is displayed:

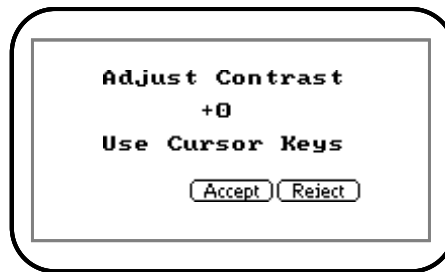

Adjust Contrast

- 4) Press 'Key 3 - Scroll Left' and 'Key 6 - Scroll Right' to adjust the value displayed.
- 5) Press the soft-key 'Accept' or 'Reject' accordingly to accept or reject the changes.

✍ Note: The manually set contrast setting is retained when the instrument is switched off.

5.12.2.3 Alarms

The G200 range of instruments has the facility to set rising or falling alarms for the main gas channels. The alarms for each channel can be enabled or disabled independently via the 'Alarms' menu option.

Once enabled these alarms become active in the 'Main Read Screen'; this is indicated by a bell 🛎 icon. If an alarm is triggered the screen turns red and a flashing bell 🛎 icon is displayed. The beeper is sounded until the gas level has recovered beyond the trigger point.

- Rising alarms are triggered when the gas level exceeds the maximum value entered by the user.
- Falling alarms are triggered when the gas level falls below the minimum value entered by the user.

- 1) From the 'Main Read Screen' press the 'Menu' key on the instrument panel.
- 2) Press 'Key 2' to display the 'Utilities' menu.
- 3) Press 'Key 3' to select 'Alarms' and the following screen is displayed:

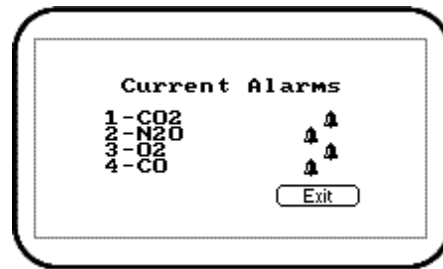

Current Alarms – G210

- 4) Press the appropriate key/option number to maintain the alarm settings. Select from the following:

1-Enabled/Disabled	Toggle between disabled and enabled alarm status.
2-Max	Sets the upper limit alarm setting.
3-Min	Sets the minimum alarm setting. The default is 0.
- 5) Select the option key to modify followed by the soft-key 'Accept' or 'Reject'.

5.12.2.4 Settings

The 'Settings' option enables the operator to maintain information with regards to taking samples and readings.

- 1) From the 'Main Read Screen' press the 'Menu' key on the instrument panel.
- 2) Press 'Key 2' to display the 'Utilities' menu.
- 3) Press 'Key 4' to select 'Settings' and the following screen is displayed:

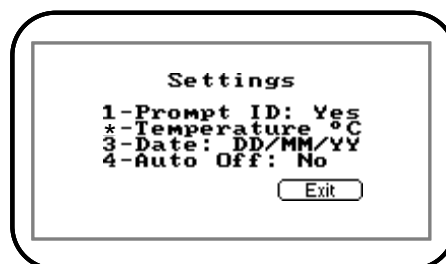

Settings

- 4) The following instrument settings may be maintained:

1-Prompt ID:	-	Press 'Key 1' to prompt for ID code for each sample reading, answer 'Yes' or 'No' accordingly.
*-Temperature:	-	This option is not available on the G200 range of instruments.
3-Date:	-	Press 'Key 3' to switch the date format between dd/mm/yy and mm/dd/yy formats.
4-Auto Off:	-	Press 'Key 4' to auto switch off the instrument when not in use. Toggle between Auto Off: Yes or No. If set to Yes, the instrument will switch off after ten minutes if not in use.

5.12.2.5 Flow Fail

The 'Flow Fail' option enables the operator to adjust the instrument flow fail detection point should it fail in normal operation with a clean filter.

The instrument's internal pump can be stalled when pulling against a vacuum or through a blocked filter. This is indicated by a flashing pump icon ; to prevent damage to the pump, the pump will switch off after a few seconds. Press the 'Pump' key again to remove the flashing pump icon.

Note: Dirty or discoloured filters should be changed before use. Filters that have drawn in water should be changed immediately to prevent damage to the instrument.

- 1) From the 'Main Read Screen' press the 'Menu' key on the instrument panel.
- 2) Press 'Key 2' to display the 'Utilities' menu.
- 3) Press 'Key' 5 to select 'Flow Fail' and the following screen is displayed:

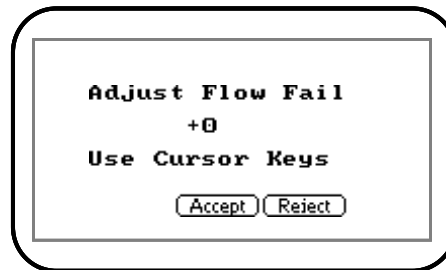

Adjust Flow Fail

- 4) Use the scroll keys 'Key 4 – Scroll Left' or 'Key 6 – Scroll Right' to adjust the value displayed. The larger the value, the less sensitive the flow fail detection is.
- 5) Press soft-key 'Accept' or 'Reject' accordingly.

For more information please refer to the following Flow Fail Process.

Flow Fail Set-up Process – Best Practice:

Make sure that you have carried out the Preliminary Checks Best Practice before commencing the Flow Fail Set-up. Refer to Section 6.1 for more information.

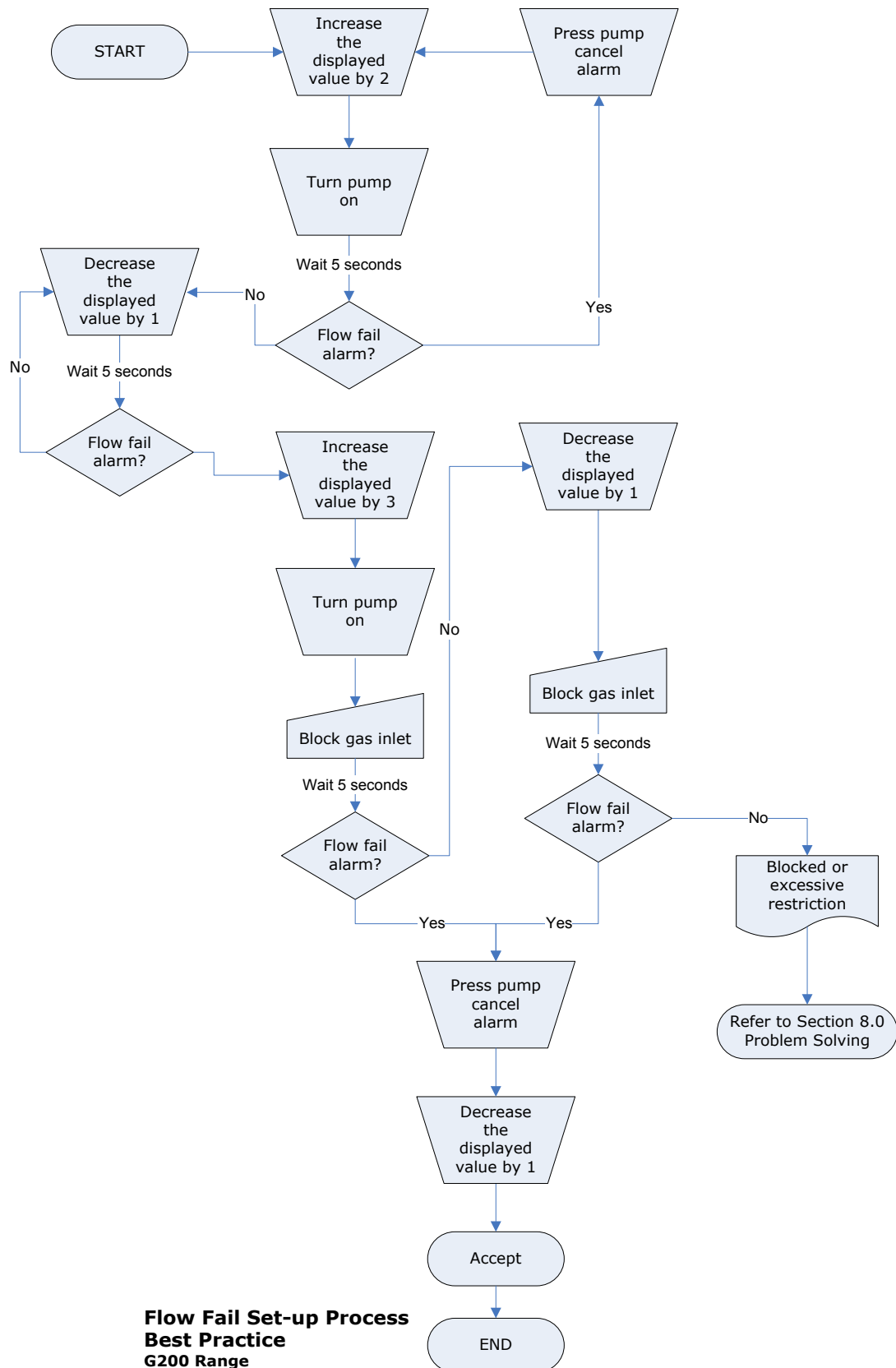

5.12.2.6 Logging

Data logging mode can be started or stopped via 'Key 6 - Logging' accessed from the 'Utilities' menu. Press 'Key 4 - Start/Stop Logging' to start and stop data logging.

Whilst in data logging mode the instrument will automatically record data at the preset intervals, including running the pump for a preset time.

Active logging mode is indicated on the 'Main Read Screen' by the  icon.

The operator is able to edit the default ID, pump run-time interval, set IDs and start/stop logging.

- 1) From the 'Main Read Screen' press the 'Menu' key on the instrument panel.
- 2) Press 'Key 6' to display the 'Logging' menu and the following screen is displayed:

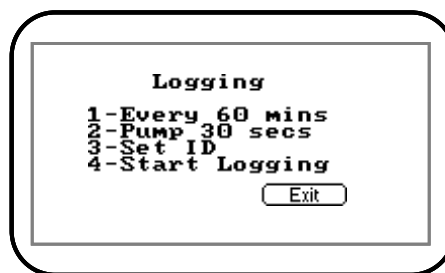

Logging Menu

- 3) Select the desired option by pressing 'Keys 1 to 4'. Then enter the appropriate setting using the keypad followed by the 'Enter' key.
 - 1-Every 00 mins. - Press 'Key 1' to enter the time in minutes for the time frame between sample readings. The interval controls the reading frequency in minutes, i.e. every ten minutes.
 - 2-Pump 00 secs. - Press 'Key 2' to enter the time in seconds for the length of time you wish the pump to run when taking a sample reading. The pump run-time is the time in seconds for which the pump runs prior to the reading being stored. This figure will also need to take into account the length of sample tube and the volume of the sample gas. For example, there is little point setting a pump run-time of ten seconds if it takes 30 seconds to draw in a new sample.
 - 3-ID Set ID - Press 'Key 3' to create eight digit alpha-numeric 'Site' and 'ID' identifiers.
 - 4-Start/Stop Logging - This option is only available once an I.D. has been created by the user. Press 'Key 4' to start and stop data logging.

 Note: Data logging mode is automatically stopped when the instrument is switched off or if the logging parameters are edited.

5.12.2.7 Reset

The instrument can be reset by pressing 'Key 7 - Reset' accessed via the 'Utilities' menu. Selecting this option will clear all user settings and any stored data including the event log.

The following warning message will be displayed 'This will clear user calibration and readings! Are you sure?' The operator is prompted to either select the 'Accept' button to continue or select the 'Exit' button to abort the reset operation.

If the operator chooses to accept a confirmation code (12345678) must be entered to confirm that a reset is really required.

5.12.3 Calibration

The G200 range of instruments is fully calibrated during manufacture and when returned for service. However, to improve accuracy between services a user/field calibration can be performed.

✍ Note: For further information please refer to section '7.0 Calibration' of this manual.

5.12.4 View Data

The 'View Data' option enables the operator to view the stored readings.

- 1) From the 'Main Read Screen' press the 'Menu' key on the instrument panel.
- 2) Press 'Key 4 - View Data' to view the stored data readings and the following screens are displayed:

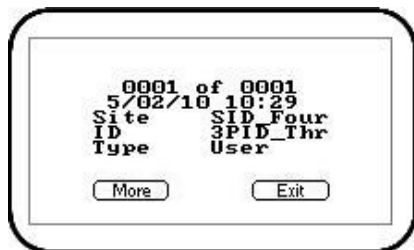

View Data – Screen 1

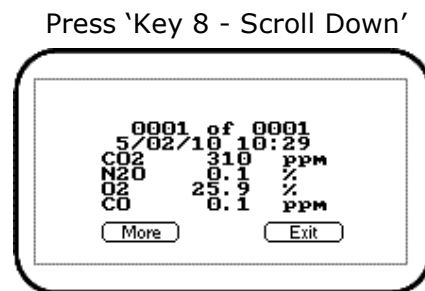

View Data – Screen 2

- 3) Press 'Key 4 - Scroll Left' and 'Key 6 - Scroll Right' to move through the stored readings either forwards or backwards. Press 'Key 2 - Scroll Up' and 'Key 8 - Scroll Down' to switch between the first and second group of reading parameters.
- 4) Press the soft-key 'More' and the following menu is displayed:

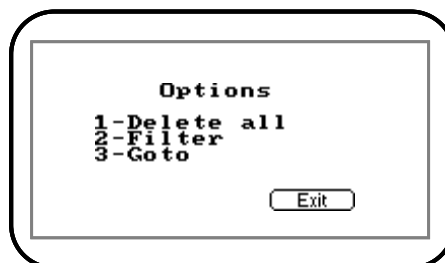

View Data – Soft-key 'More'

The 'View Data' option also enables the operator to clear the readings memory, filter the data to view or go to specific data readings listed.

- 1-Delete All - Enables the operator to delete all the readings stored,
- 2-Filter - Used to refine/filter the range of readings displayed by ID or date ranges. Press between two dates, after a date, before a date or all dates.
- 3-Go to - Enables the operator to jump to the first or last reading in the memory or any other reading.

5.12.4.1 Delete All

The 'Delete All' function enables the user to check how many readings have previously been taken and clear them if necessary.

Note: Before readings are actually deleted a caution message is displayed; once readings have been deleted they cannot be recovered. To enable TWA to be calculated the last 24 hrs worth of readings are stored.

The instrument can store up to 1,000 readings. The reading structure is fixed and may contain optional parameters not activated for your particular instrument configuration, i.e. oxygen, temperature and humidity.

Once the reading memory is full it is not possible to store any more readings. When full and the 'Store' key is pressed or data logging is activated the instrument will show a brief message stating that the memory is full and that no further data will be recorded.

- 1) From the 'Main Read Screen' press the 'Menu' key on the instrument panel.
- 2) Press 'Key 4 - View Data'.
- 3) To clear the readings press the soft-key 'More' followed by 'Key 1 - Delete all'.

5.12.4.2 Filter

The 'Filter' function enables the user to filter the data readings using all or any combination of the following filter options:

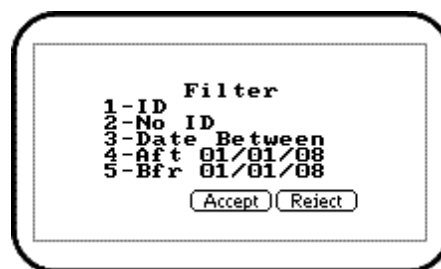

Filter Data Readings

- 1) From the 'Main Read Screen' press the 'Menu' key on the instrument panel.
- 2) Press 'Key 4 - View Data'.
- 3) To clear the readings press the soft-key 'More' followed by 'Key 2 - Filter'.
- 4) Press the appropriate menu key to select the required filter option and enter the filter data.

- 5) Select the 'Accept' button to confirm the filter selection.

5.12.4.3 Goto

The 'Goto' function enables the operator to view the first, last or specific number of readings stored.

- 1) From the 'Main Read Screen' press the 'Menu' key on the instrument panel.
- 2) Press 'Key 4 - View Data'.
- 3) To clear the readings press the soft-key 'More' followed by 'Key 3 - Goto'.
- 4) Select either 'First', 'Last' or 'Num'. If 'First' or 'Last' is selected the appropriate data will be displayed.
- 5) If 'Num' is selected the operator is prompted to enter the data reading number followed by the 'Accept' button to confirm the selection.

5.12.5 Diagnostics

The 'Diagnostics' option enables Geotech Technical Support to identify and resolve issues with the instrument and readings. If required, the operator may be asked to confirm the diagnostics displayed.

- 1) From the 'Main Read Screen' press the 'Menu' key on the instrument panel.
- 2) Press 'Key 5' to view diagnostics.

✍ Note: For further information contact Technical Support at Geotechnical Instruments (UK) Limited on +44(0)1926 338111 or email technical@geotech.co.uk.

5.12.6 Monitor (G200 ONLY)

The 'Monitor' option enables the operator of a G200 instrument to choose from the following three monitoring modes.

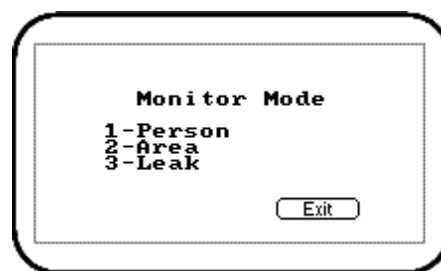

Monitor Mode

- 1) From the 'Main Read Screen' press the 'Menu' key on the instrument panel.
- 2) Press 'Key 6' followed by the relevant option key to select the required monitoring mode.

Person:

'Person' enables the operator to monitor in personal safety mode. This mode automatically stores an average N₂O reading every 15 minutes. This is used to calculate and display an

eight hour TWA (time weighted average) reading which is the operator's personal exposure level to N₂O over their working day (often called OEL - occupational exposure limit).

The TWA is measured over a 24 hour period.

The TWA calculation used by the instrument is that described by the Health and Safety Executive EH40/2002 Occupational Exposure Limits 2002. The TWA is represented mathematically by the following equation:

$$(C_1T_1 + C_2T_2 \dots C_nT_n) / 8\text{hrs.}$$

Where C₁ is the average reading for the time period T₁.

In this mode the instrument will alarm when the operator has exceeded the recommended TWA limit (the OEL for N₂O = 100ppm). This operating mode incorporates a confidence chirp which sounds every 30 seconds to give the operator confidence that the monitor is still operating correctly. There is also an option which allows the operator to set an additional alarm for the actual N₂O level, i.e. greater than 300ppm.

It is possible using Analyser Data Manager to change the OEL level for the TWA limit (default 100ppm). We would also recommend that the operator changes the 'Site' and 'ID' fields to 'Site' and 'Name' using the 'Configuration' tab.

Once IDs have been selected and accepted, readings commence immediately and are monitored continuously. To stop monitoring the operator selects the soft-key 'Person', enters the stop code 5709 and presses the 'Enter' key. Readings are automatically stored.

The following points should be noted.

- 1 The 15 minutes averages used for the TWA calculation are the result of readings taken each second. Thus short peaks of concentration will be correctly recorded and added into the TWA
- 2 If the instrument is turned off when in 'Person' mode, the readings will be assumed to be zero for the TWA calculation during the time when the instrument is off.
- 3 The TWA value displayed on the instrument is not downloaded to Analyser Data Manager (ADM). ADM recalculates the TWA based on the downloaded raw data and user set parameters.

Area:

'Area' enables the operator to monitor in area or room mode. This mode automatically stores a rolling average N₂O reading every 'n' minute(s). It is indicated by 'AV' on the screen.

The calculation is represented mathematically by the following equation: $(C_1 + C_2 \dots C_n) / \text{elapsed time in hrs.}$

This mode would typically be used to monitor a ventilation system in an operating theatre or similar where N₂O is used throughout the day with different people coming and going. Primarily for room or area monitoring, this mode is intended to give the operator a little more flexibility and can be user modified to suit the application. The monitoring interval and duration can be adjusted by the operator. There are alarm options which allow the operator to set an alarm for the average and actual N₂O levels, eg greater than 300ppm.

As with previous modes it is possible using Analyser Data Manager to change the 'Site' and 'ID' fields to 'Site' and 'Room or Area' using the 'Configuration' tab.

Once IDs have been selected and accepted, readings commence immediately and are

monitored continuously. To stop monitoring the operator selects the soft-key 'Area', enters the stop code 5709 and presses the 'Enter' key. Readings are automatically stored.

Leak Detection:

'Leak' enables the operator to monitor the instrument in leak detection mode. This extends the range of the N₂O sensor up to 10,000ppm and speeds up the response time to enable it to indicate the current level of N₂O. This allows the instrument to work as an effective leak monitor. The operator gets audio and visual feedback in addition to the displayed value to help with this. The back-light changes from green-thru-yellow to red as the gas concentration increases. And the instrument's beeper also increases in frequency and tone to further help bring attention to any gas detected. There are no additional user alarms or setting for this mode. It is not possible to store data whilst in this mode.

The operator starts and stops monitoring by selecting the soft-key 'Leak'.

Note: When monitoring gases using any of the above methods the 'Mute' key may be activated to eliminate the instrument monitoring sound.

5.13 TWA and Average Calculations in ADM

This section explains how the Average and Time Weighted Average (TWA) calculations work with the Analyser Data Manager (ADM) software.

The following parameters are optionally calculated by ADM and use the set of data currently selected in ADM by the ID, time filters and serial number selection.

Average (ppm) = (AvgN2O₁ x AvgPeriod₁ + AvgN2O₂ x AvgPeriod₂ + AvgN2O_n x AvgPeriod_n) / number-of-minutes from first to current filtered reading.

Note: The results in this column may change when the filter(s) are changed. The definition of the parameters of the calculation can be altered within ADM on the Configuration tab.

TWA (ppm) = (AvgN2O₁ x AvgPeriod₁ + AvgN2O₂ x AvgPeriod₂ + AvgN2O_n x AvgPeriod_n) / 8 hours. The data is taken as a 24 hour window extending backward through the filtered entries.

Any missing entries within the 24hr window are assumed to be 0ppm. Selecting the TWA filter affects the appearance of the data when it is charted within ADM, the data between available recorded data is shown as a zero.

The definition of the parameters of the calculation can be altered within ADM, the default configuration at installation matches the EH-40 standard.

Notes:

- The TWA, Average and OEL checkbox options in ADM are columns of data that are calculated when the data is displayed, based on the data previously downloaded and stored from the instrument. The values do not come from the instrument.
- Adding the TWA column causes ADM to show an additional 24 hours of "zero" readings so the user can see the TWA value decay back to 0.
- Adding any of these calculated columns makes more sense when choosing data from a single identifier (Person or Area) using the ID Filter.
- Adding any of these calculated columns is optional depending on the application but is provided for user flexibility.

Example of Data recorded on the Analyser in Area mode, and then ADM calculating the TWA and Average Columns.

Time/Date	SITEID	LOCID	Baro (mb)	Rdg Type	AvgN20 (ppm)	AvgPeriod (Mins)	TWA (ppm)	Average (ppm)	Serial No
02/06/2010 16:24:36	AREA	A	1014.00	Auto	9.00	15.00	0.28	9.00	IN00108
02/06/2010 16:39:36	AREA	A	1013.00	Auto	10.00	15.00	0.59	9.50	IN00108
02/06/2010 16:54:36	AREA	A	1012.00	Auto	10.00	15.00	0.91	9.67	IN00108
02/06/2010 17:09:36	AREA	A	1014.00	Auto	10.00	15.00	1.22	9.75	IN00108
02/06/2010 17:24:36	AREA	A	1014.00	Auto	11.00	15.00	1.56	10.00	IN00108
02/06/2010 17:39:36	AREA	A	1014.00	Auto	10.00	15.00	1.89	10.00	IN00108
02/06/2010 17:54:36	AREA	A	1014.00	Auto	10.00	15.00	2.19	10.00	IN00108
02/06/2010 18:09:36	AREA	A	1014.00	Auto	10.00	15.00	2.50	10.00	IN00108
02/06/2010 18:24:36	AREA	A	1014.00	Auto	9.00	15.00	2.78	9.89	IN00108
02/06/2010 18:39:36	AREA	A	1015.00	Auto	9.00	15.00	3.06	9.80	IN00108
02/06/2010 18:54:36	AREA	A	1013.00	Auto	9.00	15.00	3.34	9.73	IN00108
02/06/2010 19:09:36	AREA	A	1014.00	Auto	8.00	15.00	3.59	9.58	IN00108
02/06/2010 19:24:36	AREA	A	1014.00	Auto	8.00	15.00	3.84	9.46	IN00108
02/06/2010 19:39:36	AREA	A	1012.00	Auto	8.00	15.00	4.09	9.36	IN00108
02/06/2010 19:54:36	AREA	A	1014.00	Auto	8.00	15.00	4.34	9.27	IN00108
02/06/2010 20:09:36	AREA	A	1015.00	Auto	7.00	15.00	4.56	9.13	IN00108
02/06/2010 20:24:36	AREA	A	1014.00	Auto	7.00	15.00	4.78	9.00	IN00108
02/06/2010 20:39:36	AREA	A	1014.00	Auto	7.00	15.00	5.00	8.89	IN00108
02/06/2010 20:54:36	AREA	A	1014.00	Auto	6.00	15.00	5.19	8.74	IN00108
02/06/2010 21:09:36	AREA	A	1014.00	Auto	6.00	15.00	5.38	8.60	IN00108
02/06/2010 21:24:36	AREA	A	1014.00	Auto	6.00	15.00	5.56	8.48	IN00108
02/06/2010 21:39:36	AREA	A	1014.00	Auto	5.00	15.00	5.72	8.32	IN00108

Example of Data recorded on the Analyser in Person mode, and then ADM calculating the TWA and Average Columns.

Time/Date	SITEID	LOCID	Baro (mb)	Rdg Type	AvgN20 (ppm)	AvgPeriod (Mins)	TWA (ppm)	Average (ppm)	Serial No
03/06/2010 10:26:46	PERSON	B	1015.00	TWA	4.00	15.00	0.13	4.00	IN00108
03/06/2010 10:41:46	PERSON	B	1015.00	TWA	4.00	15.00	0.25	4.00	IN00108
03/06/2010 10:56:46	PERSON	B	1015.00	TWA	5.00	15.00	0.41	4.33	IN00108
03/06/2010 11:08:17	PERSON	B	1015.00	TWA	5.00	11.00	0.52	4.46	IN00108
03/06/2010 11:23:17	PERSON	B	1015.00	TWA	0.00	15.00	0.52	3.52	IN00108
03/06/2010 11:38:17	PERSON	B	1015.00	TWA	0.00	15.00	0.52	2.91	IN00108
03/06/2010 11:53:17	PERSON	B	1015.00	TWA	0.00	15.00	0.52	2.48	IN00108
03/06/2010 12:08:17	PERSON	B	1015.00	TWA	0.00	15.00	0.52	2.16	IN00108
03/06/2010 12:23:17	PERSON	B	1015.00	TWA	0.00	15.00	0.52	1.91	IN00108
03/06/2010 12:38:17	PERSON	B	1015.00	TWA	0.00	15.00	0.52	1.71	IN00108
03/06/2010 12:53:17	PERSON	B	1015.00	TWA	0.00	15.00	0.52	1.55	IN00108
03/06/2010 13:08:17	PERSON	B	1015.00	TWA	0.00	15.00	0.52	1.42	IN00108
03/06/2010 13:23:17	PERSON	B	1015.00	TWA	0.00	15.00	0.52	1.31	IN00108
03/06/2010 13:38:17	PERSON	B	1015.00	TWA	0.00	15.00	0.52	1.21	IN00108
03/06/2010 13:53:17	PERSON	B	1015.00	TWA	0.00	15.00	0.52	1.13	IN00108
03/06/2010 14:08:17	PERSON	B	1015.00	TWA	0.00	15.00	0.52	1.06	IN00108
03/06/2010 14:23:17	PERSON	B	1015.00	TWA	0.00	15.00	0.52	1.00	IN00108

6.0 Taking Readings

6.1 Preliminary Checks - Best Practice

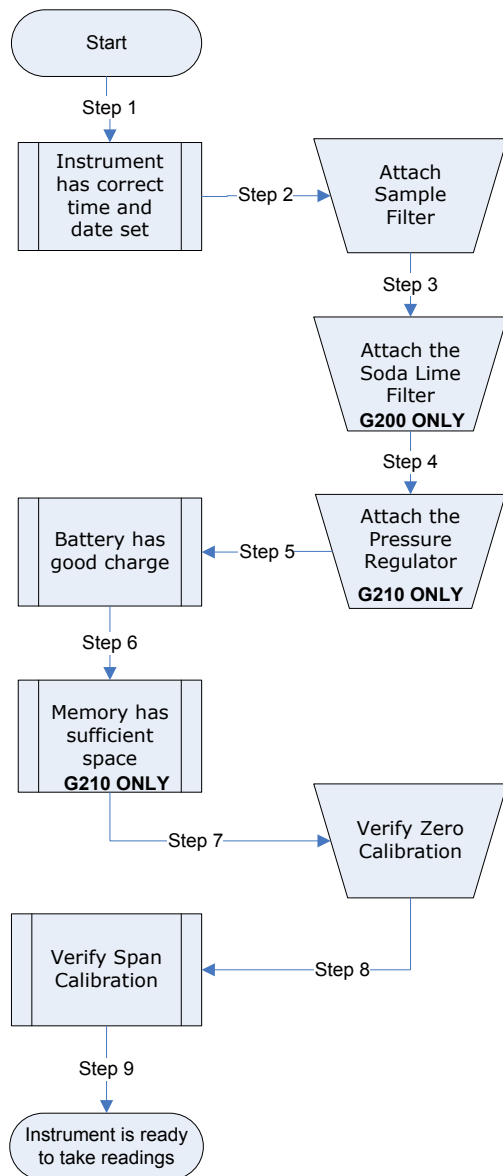

Preliminary Checks
(G200 Range - Best Practice)

Prior to use, it is good practice to ensure that:

- Step 1** The instrument has the correct time and date set.
- Step 2** Check that the sample filter is fitted and that it is clean and dry.
- Step 3** Attach the soda lime CO₂ filter (G200 model only).
- Step 4** Attach the pressure regulator kit (G210 model only).
- Step 5** The battery has a good charge (minimum 25% charge, even if only a few readings are required).
- Step 6** The memory has sufficient space available (G210 model only).
- Step 7** Verify that the main gases have been auto-zeroed, without gas concentration present.
- NOTE:** Ideally, the unit should be left to reach thermal equilibrium before zeroing, see Note in 7.5.1
- Step 8** Verify the span calibration with a known concentration calibration-check gas.
- Step 9** Instrument is ready to take readings.

- Do protect the instrument from strong direct sunlight which will quickly raise the temperature of the instrument beyond its operating range and the LCD display will appear almost black. The contrast setting cannot then alter the contrast.
- Do remember to always use the sample filter! If the sample filter becomes contaminated, change it and ensure all sample tubes are clean and dry before re-use.
- Don't place the instrument against anything hot as this may cause excessive internal temperatures which can lead to erroneous readings.
- Don't get the instrument wet, for example exposure to rain.

 Warning	Always ensure that the exhaust gases emerge in a safe manner into a well-ventilated area.
--	---

6.2 G200 Gas Measurement Process – Best Practice

Depending on preferences the exact reading procedure can change. The following methods are considered best practice and when followed correctly will allow quick and consistent readings to be recorded.

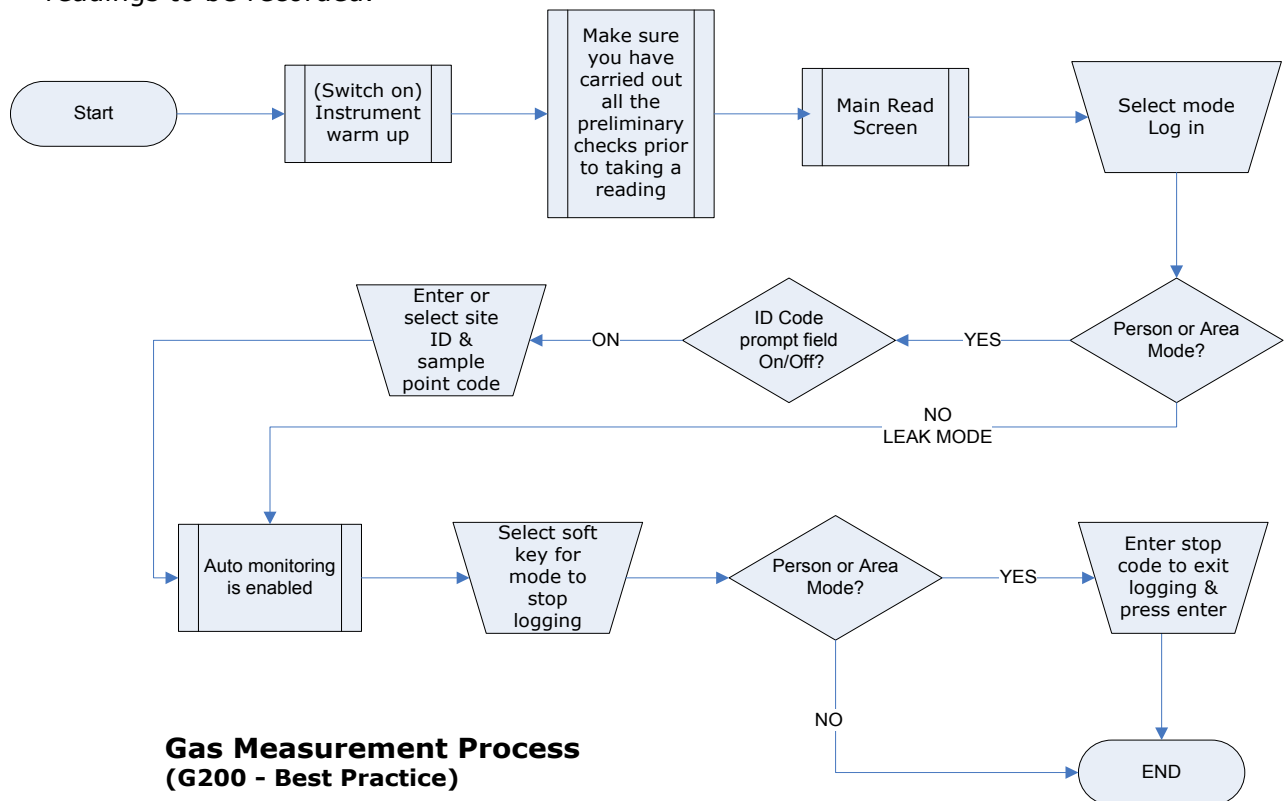

- 1) When the instrument is first switched on it should be purged with fresh air and allowed to stabilise for a few minutes.
- 2) Make sure that you have carried out all the preliminary checks as listed in section '6.1 Preliminary Checks – Best Practice' and that the instrument is ready to take the first reading. Always use a sample filter and a soda lime filter with a G200 instrument.
- 3) Connect the sample tube, if relevant, from the sample point to the inlet port of the instrument, ensuring the filter is seated correctly.
- 4) From the 'Main' menu select the mode in which you wish to operate the instrument.

Note: Although the G200 analyser is intended for use in a specific mode, i.e. Person, Area or Leak, the analyser may be used to take readings without a mode specified. For more information please refer to section '6.3 – G210 Gas Measurement Process Best Practice'.

- 5) If 'Person' or 'Area' mode is specified the operator will be prompted to enter a 'Site' and 'ID' to identify the reading. If the operator chooses to monitor readings in 'Leak' mode then no ID is required.
- 6) If operating in 'Person' or 'Area' mode readings are continuously taken by the instrument. To stop monitoring the operator must select the appropriate 'soft-key' and enter the required stop code.
- 7) If operating in 'Leak' mode the operator may start and stop monitoring by selecting the appropriate soft-key.

6.3 G210 Gas Measurement Process – Best Practice

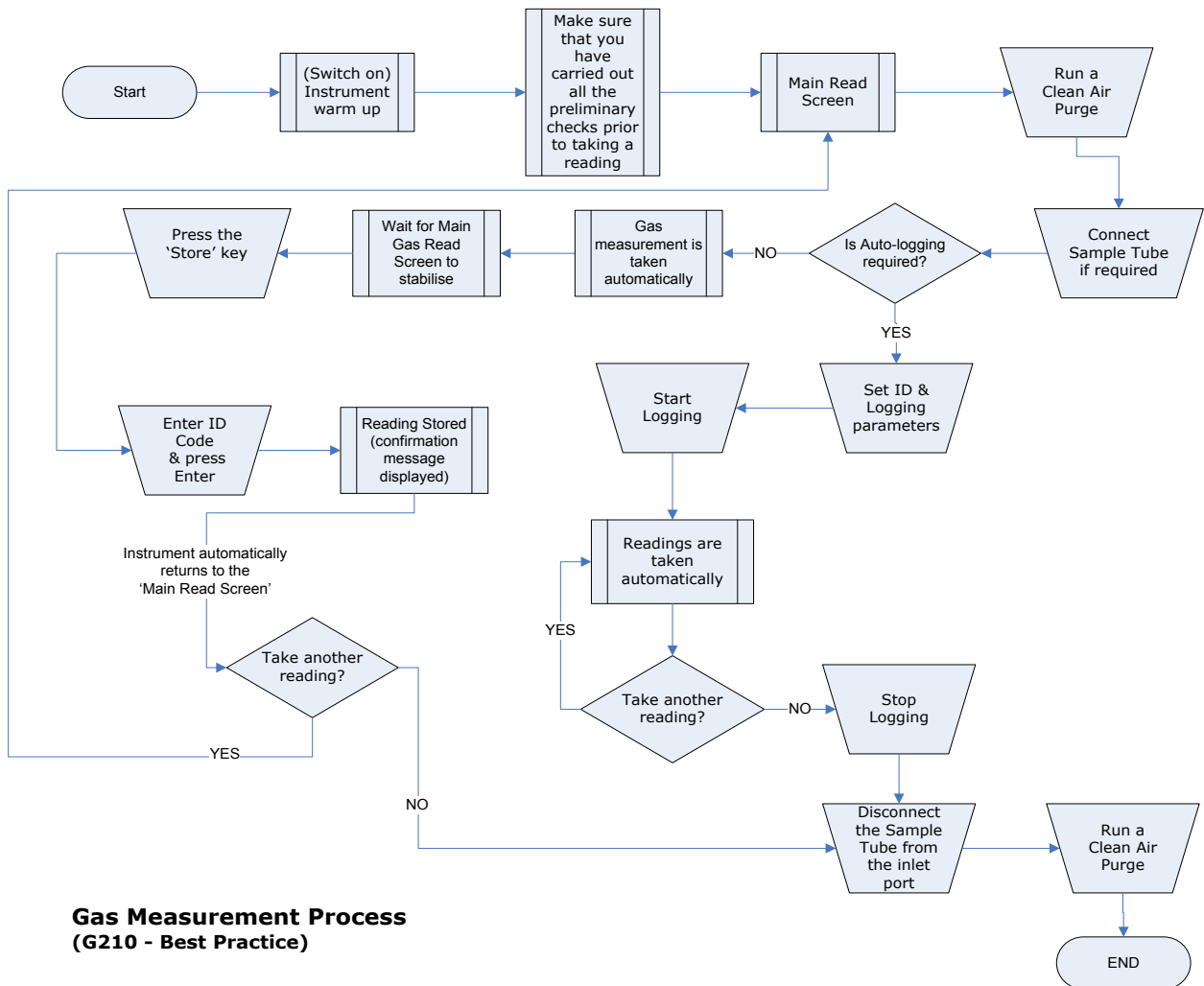

Gas Measurement Process (G210 - Best Practice)

- 1) When the instrument is first switched on it should be purged with fresh air and allowed to stabilise for a few minutes.
- 2) Make sure that you have carried out all the preliminary checks as listed in section '6.1 Preliminary Checks – Best Practice' and that the instrument is ready to take the first reading. Always use a regulator pressure kit with the G210 instrument.
 ⚠ Note: Alternative methods of pressure reduction are available and could be used. However, to avoid irreversible damage to the instrument, please seek guidance from the supplier/manufacturer before using any other pressure device.
- 3) Connect the sample tube, if relevant, from the sample point to the inlet port of the instrument, ensuring the filter is seated correctly.
- 4) If auto-logging is required select the ID codes.
- 5) If auto-logging is not required, press the pump key to draw a sample, stop the pump and press the soft-key 'Store' to store the reading. The operator will then be prompted to enter or select ID codes. Select ID codes and press the 'Accept' button to confirm. A message will display confirming that the reading has been stored.
- 6) The instrument automatically takes the operator back to the 'Main Read Screen' ready to take another reading.

7.0 Calibration

7.1 User Calibration

The G200 range of instruments is fully calibrated during manufacture and when returned for service. However, to improve accuracy between services a user/field calibration can be performed.

This section sets out the correct procedures to achieve an accurate user calibration.

⚠ Note: If the calibration is completed incorrectly it may decrease the accuracy of the instrument.

Two important terms that are used within this section are "Zero" and "Span".

Zero: The point at which the instrument is calibrated when there is none of the target gas present.

Span: The point at which the instrument is calibrated when a known quantity of the target gas is present.

7.2 Calibration Gases

User calibration of the instrument will improve the data accuracy in the range of the calibration gases used. However, it may cause less accurate readings of concentrations outside this calibrated range. Users should select the correct calibration gas for the expected gas levels on their particular application. Only use gases with a known certified gas concentration.

⚠ Note: Certified calibration gases can be supplied by Geotechnical Instruments (UK) Limited.

 Warning	For each gas used the appropriate material safety data sheet must be read and understood before proceeding. Calibration gases and the use of pressure regulators can be dangerous.
--	--

7.3 Calibration Set-up

The regulator supplied with the calibration kit has been configured to deliver a fixed flow. It only requires a few turns to open and no adjustment is necessary.

 Warning	<p>Exhaust Port</p> <p>When the instrument is being calibrated, there are two possible exits for the gas; via the usual manner out of the exhaust port of the instrument or in cases of over-pressurisation the 1/16" port on the pressure relief valve.</p> <p>It is recommended that both ports have exhaust tubing attached. The exhaust tubing must emerge in a well-vented area. Ensure there are no leaks in the tubing and connections.</p> <p>The calibration should always be carried out in a safe area with all necessary precautions taken as all pressurised gases are potentially dangerous.</p>
--	---

7.4 Calibration Equipment

The diagram below displays the regulator and tubing equipment for user calibration:

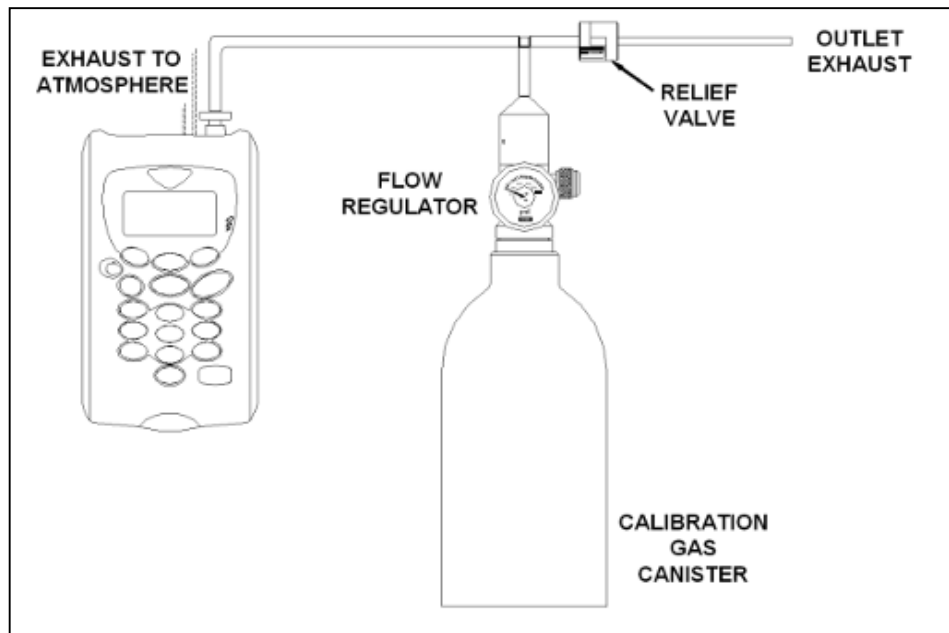

- Certified calibration gas in 58 litre gas canisters is supplied with the Geotech calibration kit. Please refer to the Geotech website www.geotech.co.uk for further information.
- The regulator supplied with the calibration kit is recommended as flow and pressure rates are factory set.

Note: Maximum input pressure 250mb maximum flow 300ml.

7.5 Calibration Method

Before you begin ensure the unit is stabilised at its working temperature before performing any of the calibration operations.

To achieve the processes set out in this section, press 'Key 3 – Calibration' from the 'Main' menu. The first screen displayed provides the option to select the gas that requires calibration.

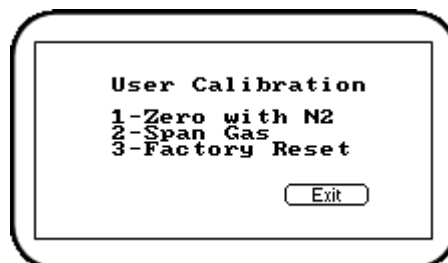

User Calibration

The exact calibration method can vary depending on the gases used.

7.5.1 Zero Calibration

For maximum accuracy it is recommended that the measurement channel is zeroed using bottled gas (certified 100% N₂). Due to the CO₂ cross-gas effect on N₂O, if nitrogen gas is not available the optional soda lime CO₂ filter kit can be fitted to the gas inlet. This allows the user to perform a zero using normal air as the soda lime CO₂ filter will absorb virtually all CO₂ from the sample air. For both these options select 'Key 1-Zero with N₂' from the user calibration menu.

Note: In normal use, it is recommended that the soda lime CO₂ filter kit is always used. This kit is not required for normal use of the G210, as it measures CO₂ as standard. For further information about cross-gas effects, refer to section '8.5 Cross-Gas Effects' of this manual.

Note: For all three of the aforementioned methods of zeroing and Air calibrating the instrument, it is preferred that the instrument is left in its 'on state' to reach thermal equilibrium before completing this process (approximately 40 minutes). However, the instrument can be zeroed or Air calibrated immediately after turning it on and then subsequently used to measure but this process must be repeated after the 40 minute thermal equilibrium time.

- 1) From the 'Main' menu select 'Key 3 – Calibration' and the following screen is displayed:

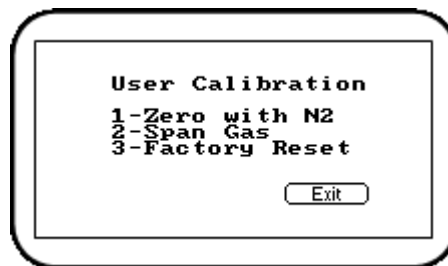

User Calibration

- 2) Select 'Key 1 - Zero with N₂' (recommended) and either attach the 100% N₂ or soda lime CO₂ filter kit.
- 3) Press the 'Start' key. The instrument will now wait (a minimum of 60 seconds) for the gas reading to stabilise at the correct level. If zeroing with the soda lime kit in fresh air press the 'Pump' key to draw in fresh air. This operation will time out after one hour if readings cannot be stabilised.
- 4) The instrument will then indicate a successful zero has been completed. Press the soft-key 'Accept' to confirm the calibration and store the new user offset. Alternatively, soft-key 'Reject' to exit without change.

Note: If the calibration failed then purge and try again or select a different air source.

If using G210 – very high concentrations of CO₂ may take up to **30 minutes** to purge completely. O₂ is not zeroed.

7.5.2 Span Channels

It is recommended that the instrument is spanned to target the desired reading range (refer to section '7.8 Recommended Gases for Calibration' of this manual for more information); ideally this should not be a low level close to zero.

- 1) If not already preset, enter the correct **span target**, i.e. certified concentration of

your calibration gas. Press 'Key 1' and enter the new value. Then attach the gas and open regulator valve to allow the gas to flow.

- 2) Press the 'Start' key and wait for the reading to stabilise. This can take a couple of minutes. Press the 'Pump' key to draw sample gas.
- 3) Once a stable reading is shown press the soft-key 'Accept'. A successful span calibration message will then be displayed. Press the soft-key 'Accept' again to confirm the calibration and 'Store' the new user span. Alternatively, press soft-key 'Reject' to exit without change.

✍ Note: If the calibration failed then try again using a longer purge time or different target gas.

7.5.3 Reset Factory Settings

This option will reset the instrument to its factory programmed calibration characteristics and will clear the user calibration points for both gas channels.

- 1) To reset to factory settings, press 'Key 1 - Factory Reset' from the 'Calibration' menu.

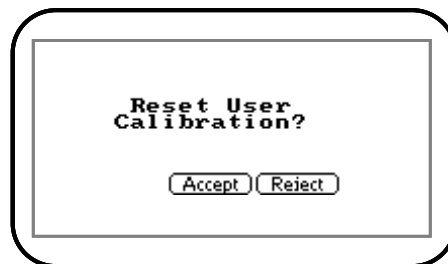

User Calibration - Reset

- 2) To prevent the user calibration data being accidentally erased the user must confirm the action by pressing the soft-key 'Accept', or soft-key 'Reject' to exit without change.

7.6 Last Field Calibration

This data can be found in the 'Information' screen accessed via the 'Utilities' menu. This option displays the date that the last field calibration was performed on the instrument.

7.7 Calibration Record

The G200 instruments have the facility to log user calibrations via the 'Event Log'. This can be used as an aid in ensuring that gas measurements are valid and accurate.

During calibration the instrument will record the following in the event log. For each entry the time and date will be stored.

Event	Data Recorded
Successful user zero for selected gas	Type (N ₂ or Air) and Readings before and after

Successful user span for selected gas	Target Value, Readings before and after
Successful user span for selected gas	Target Value, Readings before and after
Failed user zero for selected gas	Type (N ₂ or Air) and Reading
Failed user span for selected gas	Target Value, Gas Reading
Failed user span for selected gas	Target Value, Gas Reading
Return to factory settings	

✎ Note: If the calibration failed, then try again using a longer purge time or different target gas. This event log can only be downloaded and viewed via the optional Analyser Data Manager software. It cannot be viewed on the analyser screen.

7.8 Recommended Gases for Calibration

The calibration gas recommended depends on the desired operation and concentration of target gas. The following table outlines the recommended gases that can be used for calibrating each of the measurements.

Instrument	G200		G210	
	OEL	Leak	N ₂ O 50%, O ₂ 50%	O ₂ 100%, N ₂ O
Zero Calibration Gases				
N₂ 100%	N ₂ O	N ₂ O	O ₂ , N ₂ O, CO, CO ₂	O ₂ , N ₂ O, CO, CO ₂
Span Calibration Gases				
N₂O 100ppm	N ₂ O			
N₂O 500ppm		N ₂ O		
O₂ 100%				O ₂
N₂O 50%, O₂ 50%			N ₂ O, O ₂	
N₂O 100%				N ₂ O
CO 100ppm, CO₂ 500ppm			CO, CO ₂	CO, CO ₂

7.9 G200 Range Calibration – Best Practice

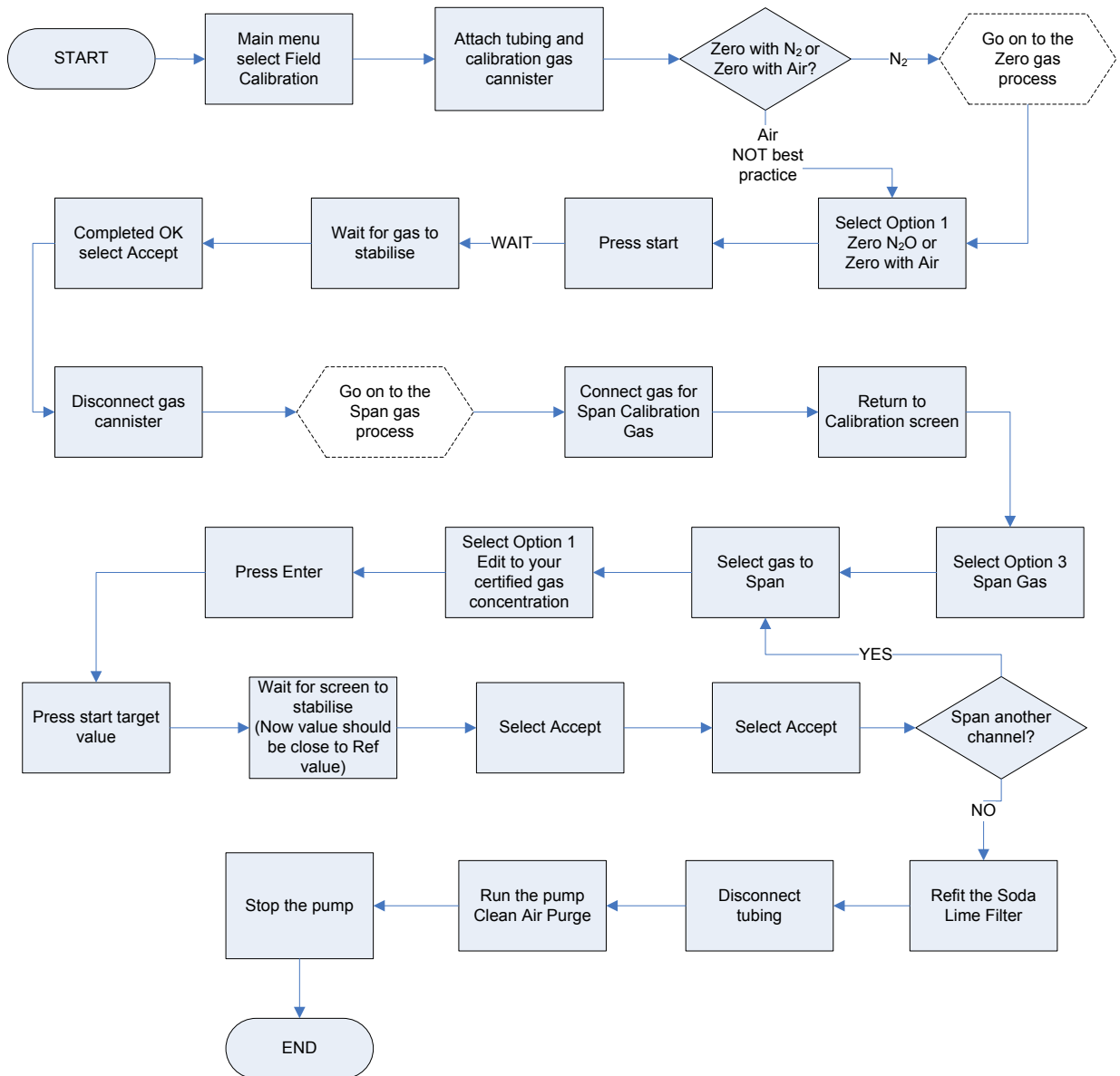

8.0 Problem Solving

This section outlines various warning and error messages which the operator may receive during general operation of the instrument. For further assistance please contact Technical Support at Geotechnical Instruments (UK) Limited on +44(0)1926 338111 or email technical@geotech.co.uk.

8.1 Warnings and Errors

When switched on the instrument will perform a predetermined self-test sequence taking approximately 15 seconds. During this time many of the instrument's working parameters and settings are checked.

If any operational parameters are out of specification or if the pre-programmed recommended calibration/service date has passed, errors or warnings may be displayed.

Use the 'Scroll Up' and 'Scroll Down' keys to move through the list if required.

There are two types of warning that may be displayed:

- General warnings that may not affect the instrument's function and those where the self-test has detected a function that is outside the usual operating criteria, e.g. battery charge low, memory nearly full.
- Operational parameters that could affect the performance of the instrument, e.g. N₂O out of calibration.

The most likely reason for these errors is either an incorrect user calibration or they may indicate sensor failure. If an incorrect user calibration has caused the warning it should be correctable by way of returning the instrument to factory settings, zeroing or carrying out a user calibration as necessary for the relevant function.

Under and Over Range Codes

If a reading is over range (i.e. above the maximum allowed reading) it will be displayed with more than chevrons (>>.>). This can occur if a channel has been incorrectly calibrated or the sample gas has exceeded its specified range (e.g. N₂O > 20%).

If a reading is under range (i.e. below zero) it will be displayed with less than chevrons (<<. <). Refer to section '7.0 Calibration' of this manual to remedy under-range by performing a user zero.

A number displayed as asterisks (**.*) indicates an error, usually where the instrument has been unable to complete a particular calculation. Typically, this will be the first indication of a fault condition.

Where no data is available dashes (--.-) are displayed. This usually occurs when a particular reading or parameter has been skipped by the user, or where an optional accessory is not fitted correctly, i.e. a temperature probe.

8.2 Battery No Charge Reset

Should the instrument completely run out of charge (so low that memory is lost), upon recharging, the instrument will force the operator to re-enter the time and date parameters. No other data is lost.

8.3 Self-test Warning Messages

The following warnings may be displayed during the self-test period when the instrument is switched ON.

Warning		Description
Check Memory		The instrument only has space to store less than 50 readings before it is full. The exact number can be checked using the 'View Readings' option.
Memory Full		There is no more space in memory to store readings. Both the store and log options will be disabled until the memory is cleared. The readings should be downloaded to PC using the optional download software before memory is cleared.
Battery Low	⏻	The instrument does not have enough power to operate for a full day. The instrument should be recharged or connected to an external power supply.
Service Due	🔧	It has been 12 months (or more) since the instrument was returned to the manufacturer for a service. The performance and accuracy of the instrument may be impaired.
Low Flow		The instrument's gas inlet (or outlet) may be blocked. This warning is most commonly caused by a water-logged or dirty sample filter. Change the sample filter and check for obvious blockages in the sample tubes. Alternatively, a small amount of adjustment can be made to the low flow detection point to compensate for minor changes in the performance of the pump fitted to the instrument.
Check N ₂ O Cal.		This warning is most commonly caused by an incorrect user calibration. Try recalibrating the sensor or press 'Return to factory settings'. If the warning persists it may be caused by dirt or damage to the infrared sensor. The instrument will need to be returned to the manufacturer for service/repair.
Check O ₂ Cal.		This warning is most commonly caused by an incorrect user calibration. Try recalibrating the sensor or press 'Return to factory settings'. If the warning persists it may be caused by a damaged or faulty sensor. The instrument will need to be returned to the manufacturer for service/repair.
Ref. Fault		This may be caused by dirt or damage to the infrared sensor in the instrument. The instrument will need to be returned to the manufacturer for service/repair.
*Invalid Config.		The instrument has detected a problem with the configuration parameters most likely caused after a firmware update. The instrument will need to be returned to the manufacturer for service/repair.
Change O ₂ Cell	🔧	The oxygen cell has not been changed for at least 3 years; its performance and accuracy may be impaired. The instrument will need to be returned to the manufacturer for service.

Warning		Description
Change CO Cell	Y	The carbon monoxide cell has not been changed for at least 2 years; its performance and accuracy may be impaired. The instrument will need to be returned to the manufacturer for service.
Change Pump	Y	The pump has exceeded its recommended run-time and should be changed. The instrument will need to be returned to the manufacturer for service.
Change Battery	Y	The Lithium Ion battery has exceeded its recommended life-time or number of charge cycles and should be changed. The instrument will need to be returned to the manufacturer for service.
User Cal. Due		It has been over a month since the instrument was last user calibrated. For optimal performance and accuracy it is recommended that the instrument is user calibrated each time it is used.
Invalid Time		The instrument has an invalid time. This is most likely to occur after a reset. The correct time should be entered using the set 'Time & Date' option via the 'Utilities' menu.
Invalid Date		The instrument has an invalid date. This is most likely to occur after a reset. The correct date should be entered using the set 'Time & Date' option via the 'Utilities' menu.
Baro. Fault		The instrument has detected a fault with the barometric sensor or its calibration. This will have an effect on the accuracy of the readings as they are pressure compensated. The instrument will need to be returned to the manufacturer for service.
**Sensor n Failed		Sensor n is expected but not reading a valid value. This is generally a hardware fault or the instrument has been configured incorrectly. Please contact the manufacturer.
** Sensor n Range		Sensor n raw value is outside expected range. This is generally a hardware fault or the instrument has been configured incorrectly. Please contact the manufacturer.
**Sensor n Stability		Sensor n has not reached a stable value within the warm-up time limit. The instrument may have been left with gas in. Please purge and retry. If the instrument shows a stable reading on the main screen this warning can be ignored.

☞ Note: *Certain configuration problems can be corrected remotely.
 ** Where n equals the sensor channel number.

Using the Analyser Data Manager software, it is possible to export the current configuration and e-mail it to the manufacturer's Technical Support or Service Department. Depending on the type of error it may be possible to correct the configuration file and import it back into the instrument. For further information please contact Geotech Technical Support on +44(0)1926 338111.

8.4 User Calibration Trouble Shooting

Error	Remedy
User Zero failed	A possible reason for this is that the instrument is trying to zero to a level which is outside the predetermined range set when the unit was calibrated at the factory. To rectify this, first ensure the unit contains absolutely none of the gas which is being zeroed by flushing thoroughly with nitrogen. If it will not zero, then refer to the instructions given in the 'Factory Settings' section. If the instrument continues to fail to zero then the unit must be returned to the manufacturer for investigation.
Calibration failed	Check the span target is set to the correct value, if not, correct and retry spanning the channel. Repeat the entire procedure, including zeroing the channel and then calibrate the span. Ensure the reading is stable before spanning the channel.

User Calibration Explained:

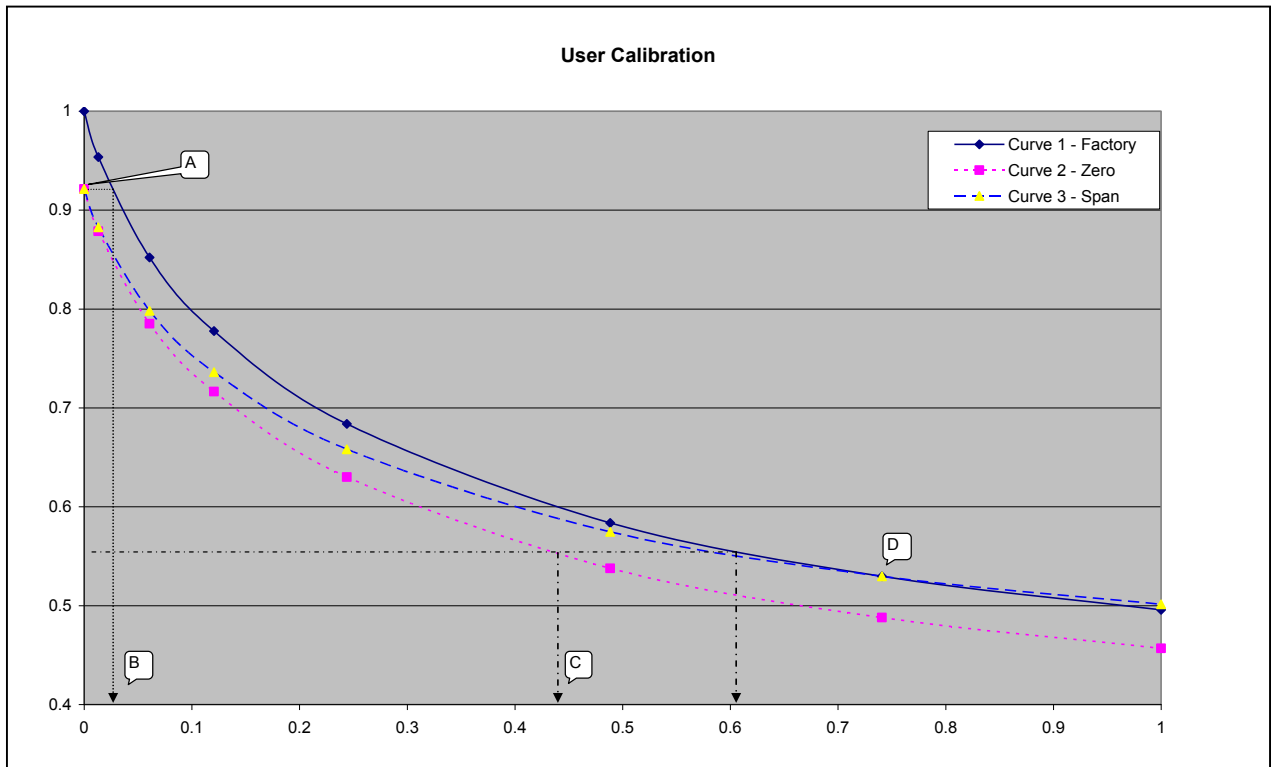

User calibration is a means of optimising the performance of the instrument to the current operating conditions such as ambient temperature and pressure as well as correcting for instrument drift caused by lamp and filter settling.

In general, the instrument should not require calibration more than once a month, but we do recommend verifying the instrument's operation each day.

User calibration has two operations and each may be performed individually, however for a complete user calibration both must be completed.

Factory Calibration (Curve 1)

The G200 instruments are 'Factory' calibrated and stable.

Zero Calibration (Curve 2)

This corrects the entire curve for lamp and filter variations caused by aging and user induced drift due to dirt etc. If done correctly there is often no need to complete a span calibration. However, a poor calibration [A] will result in a span error as shown with the zero indicating a small error [B] but a significant span error [C].

⚠ Note: The zero calibration is very sensitive and even 100% instruments will detect in the 0 to 100ppm range even though they do not display to this resolution. Please refer to the chart 'Typical Zero Gas Purge Time'.

Span Calibration (Curve 3)

This optimises the instrument at the span calibration concentration [D] for the current operational conditions and variations in user calibration gases. It corrects the span point leaving the zero unadjusted and should be done at the concentration of normal operation.

Typical Calibration Purge Times

Typical zero calibration although displaying zero needs to be given time to settle. We recommend commencing the calibration at least five minutes after the display concentration stabilises.

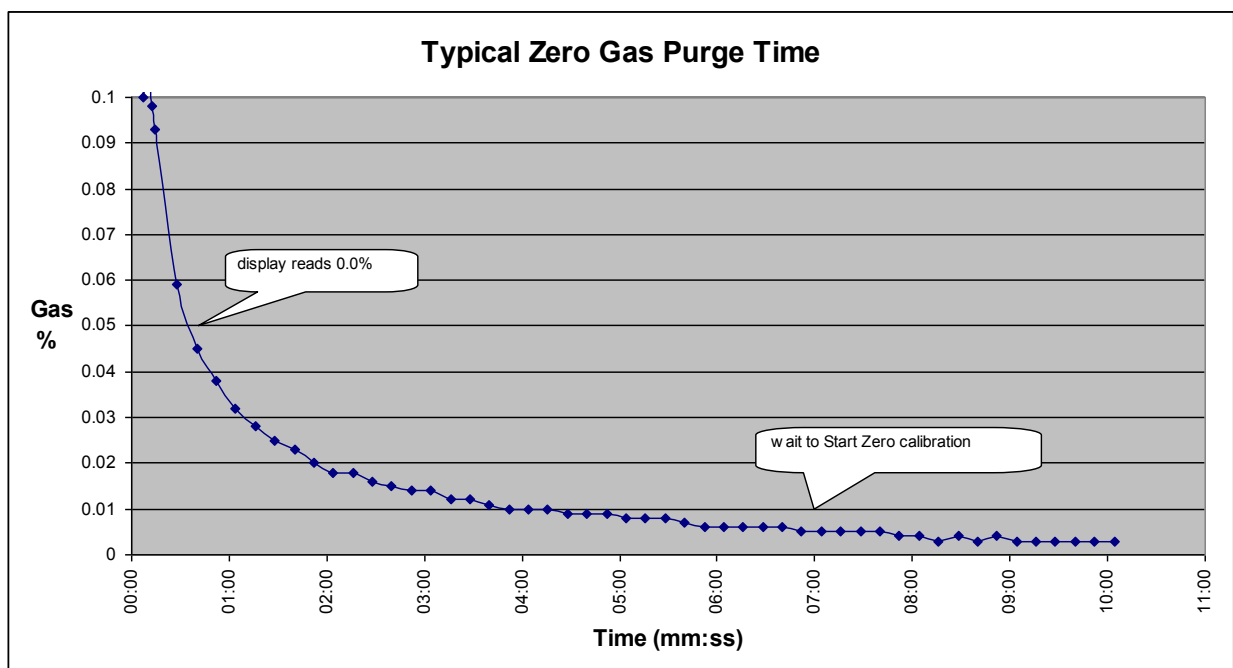

8.5 Cross-Gas Effects

CO₂ Cell:

Carbon dioxide is measured by infrared absorption at a wavelength specific to carbon dioxide. There is a small cross interference of 1,000:1 from N₂O which is compensated for within the G210. Therefore, the carbon dioxide reading will not be affected by any other gases.

O₂ Cell:

The oxygen sensor is a galvanic cell type and suffers virtually no influence from CO₂, CO, H₂S, NO₂, SO₂ or H₂, unlike many other types of oxygen cell.

N₂O Cell:

Nitrous oxide is measured by infrared absorption at a wavelength specific to nitrous oxide

and suffers virtually no influence from CO, H₂S, NO₂, SO₂ or H₂.

✍ Note: To compensate for the influence of N₂O on the CO₂ it is important the Zero and N₂O Span calibrations do not contain CO₂. CO₂ will have an influence on the N₂O channel. It is recommended that the Soda Lime CO₂ filter is used.

CO Cell:

Carbon monoxide is measured by an electrochemical gas sensor. It is not affected by the other measurement gases but can have cross interference from gases not normally present in medical supply gases and suffers virtually no influence from CO₂, H₂S, NO₂, SO₂.

8.6 Hardware Reset

If for any reason the instrument 'locks up' and will not switch off, or the instrument appears off and will not turn on, it is possible to force an emergency power off. Pressing and holding the 'On/Off' key for 10 seconds will power off the instrument. Once this time has elapsed, the instrument can be powered on as normal.

✍ Note: Performing a hardware reset may cause loss or corruption of currently stored data including the time/date.

9.0 Service

The G200 and G210 instruments should be regularly serviced to ensure correct operation and accurate readings. The manufacturer recommends a full service and recalibration **every 12 months**.

Depending on usage the O₂ cell should be replaced every 2-3 years. The CO cell will require replacement after 1 or 2 years again depending on usage.

User Serviceable Parts

✍ Note: There are no user serviceable parts inside the instrument. Please do not attempt any repair as this may invalidate any warranty supplied with your instrument.

The following parts are supplied by your instrument manufacturer and can be user serviced:

Sample Filter	This should be regularly inspected for damage or discolouration and changed if needed. The instrument should never be operated without the sample filter as this may result in water or dust entering the instrument. The filter should be changed immediately if water can be seen. Failure to do so can damage the instrument.
Sample Tubing	Always ensure that sample tubes are not contaminated or damaged.
Soda Lime CO ₂ Filter	This should be regularly inspected for damage or discolouration and changed if needed. The G200 instrument should never be operated without the soda lime CO ₂ filter as any CO ₂ will cross-contaminate the N ₂ O reading.

Cleaning

The instrument and accessories (including power supply unit) can be wiped clean using a non-fibrous damp cloth.

✍ Note: Do NOT apply pressure to the LCD display as this can cause damage.

Do NOT use solvents or any other chemical cleaners.

10.0 Warranty Policy

This instrument is guaranteed, to the original end user purchaser, against defect in materials and workmanship for a period of **12 months** from the date of the shipment to the user.

During this period Geotechnical Instruments (UK) Limited will repair or replace defective parts on an exchange basis.

The decision to repair or replace will be determined by Geotechnical Instruments (UK) Limited.

To maintain this warranty, the purchaser must perform maintenance and calibration as prescribed in the operating manual.

Normal wear and tear, and parts damaged by abuse, misuse, negligence or accidents are specifically excluded from the warranty.

 Note: Please contact Technical Support at Geotechnical Instruments (UK) Limited for further information.

11.0 Event Log

The following events are recorded in the instrument's event log. The event log can only be downloaded using the additional Analyser Data Manager software. Please refer to the Analyser Data Manager operating manual for further details.

Event	Data
Cold Start/Reset	Type of start (MCUSR, boot_key)
Firmware version	Description
Set time	Before and After
Set date	Before and After
Re-flash requested	None
Restore to factory settings	Type
Comms clear memory	Type 0=Readings, 1=Event Log
Change contrast	Before and After
Change flow fail current limit	Before and After
RTC date/time invalid	None
Factory calibration invalid or overdue	Date, Difference
Service invalid or overdue	Date, Difference
Field/User Calibration invalid or overdue	Time, Channel, Date, Age, Limit
O2 Cell replacement overdue	Time, Channel, Date, Age, Limit
Pump replacement overdue	Used, Limit
Battery replacement overdue	Used, Limit
EEProm settings set to default	Which
Missing EEPROM settings initialised	Which, Orig Version, New Version
CO cell replacement overdue	Time, Channel, Date, Age, Limit
Power on self-test, sensor not found	Channel
Power in self-test, sensor out of range	Channel, Reading, Low, High
Power on self-test, sensor out of range	Channel, Reading, Prev
Battery dropped below critical value	Limit, Actual
User calibration set zero OK	Before and After
User calibration set span OK	Before, After

User calibration set zero failed	Target, Reading
User calibration set span failed	Target, Reading
Attempt to store when readings memory full	Max
Readings memory nearly full	Limit, Actual
Flow fail current limit exceeded	Limit, Actual
Automatic power off	
Change logging mode	Status, Interval, Pump time
Change logging mode ID	ID
Changing logging mode ID site	Site ID
Flow fail current limit exceeded	Limit, Actual
An alarm has changed state	Alarm, State, Actual, High, Low
Change of alarm setting	Alarm, State, High, Low
Mode of instrument changed	Before, After

12.0 Certificate of Calibration

A certificate of calibration is supplied at the time of purchase and updated when the instrument is serviced. For example:

CERTIFICATION OF CALIBRATION											
 <p style="margin: 0;">Geotech <small>A subsidiary of LAMTEC</small></p>	<p style="text-align: center;">ISSUED BY: GEOTECH LABORATORY</p> <p>Date Of Calibration: 16 December, 2009</p> <p>Certificate Number: IN00106 3/4161</p>										
<p>GEOTECHNICAL INSTRUMENTS Sovereign House, Queensway, Leamington Spa, Warwickshire, CV31 3JR United Kingdom Tel: +44 (0) 1926 338111 Fax: +44 (0) 1926 338110 E-mail: service@geotech.co.uk Web site: www.geotech.co.uk</p>											
<p><i>Customer:</i></p>	<p style="text-align: right;">Page 1 of 1 Pages Approved by Signatory Lynne Gibbs Laboratory Inspection</p>										
<p><i>Description:</i> Medical Gas Analyser <i>Model:</i> G200 <i>Serial Number:</i> IN00106</p>											
<table border="1" style="width: 100%; border-collapse: collapse; text-align: center;"> <thead> <tr> <th colspan="2" style="padding: 2px;">Nitrous Oxide (N2O)</th> </tr> <tr> <th style="padding: 2px;">Certified Gas (ppm)</th> <th style="padding: 2px;">Instrument Reading (ppm)</th> </tr> </thead> <tbody> <tr> <td style="padding: 2px;">100.00</td> <td style="padding: 2px;">91.33</td> </tr> <tr> <td style="padding: 2px;">500.00</td> <td style="padding: 2px;">490.50</td> </tr> <tr> <td style="padding: 2px;">900.00</td> <td style="padding: 2px;">884.67</td> </tr> </tbody> </table>		Nitrous Oxide (N2O)		Certified Gas (ppm)	Instrument Reading (ppm)	100.00	91.33	500.00	490.50	900.00	884.67
Nitrous Oxide (N2O)											
Certified Gas (ppm)	Instrument Reading (ppm)										
100.00	91.33										
500.00	490.50										
900.00	884.67										
<table border="1" style="width: 100%; border-collapse: collapse; text-align: center;"> <thead> <tr> <th colspan="2" style="padding: 2px;">Barometer (mb)</th> </tr> <tr> <th style="padding: 2px;">Reference</th> <th style="padding: 2px;">Reading</th> </tr> </thead> <tbody> <tr> <td style="padding: 2px;">1000mb</td> <td style="padding: 2px;">1002mb</td> </tr> </tbody> </table>		Barometer (mb)		Reference	Reading	1000mb	1002mb				
Barometer (mb)											
Reference	Reading										
1000mb	1002mb										
<p>All concentrations are molar. N2O, CO2 readings recorded at: 28.0°C O2 readings recorded at : 19.0°C Barometric Pressure : 1000mb</p> <p>Method of Test: The analyser is calibrated in a temperature controlled chamber using reference gases.</p> <p style="text-align: center;">End of Certificate</p>											

Sample

13.0 Important Notice to All Customers**WEEE COMPLIANT**

The wheeled bin symbol now displayed on equipment supplied by Geotechnical Instruments (UK) Limited signifies that the apparatus must not be disposed of through the normal municipal waste stream but through a registered recycling scheme.

The Waste Electrical and Electronic Equipment directive (WEEE) makes producers responsible from July 1st 2007 in meeting their obligations, with the fundamental aim of reducing the environmental impact of electrical and electronic equipment at the end of its life.

Geotechnical is now registered with the Environmental Agency as a producer and has joined a recycling scheme provider who will manage and report on our electrical waste on our behalf.

Our Producer Registration Number is WEE/GB0052TQ

So when your instrument is at the end of its life, please contact the Sales team at Geotechnical Instruments (UK) Limited who will advise you on the next step in order to help us meet our obligations.

14.0 EC Declaration of Conformity

Products	G100 range of gas analysers G200 range of gas analysers
----------	--

Geotechnical Instruments (UK) Limited declares that the item(s) described above is/are in compliance with the following standards:

EMC Directive 2004/108/EC

EN 50270 :2006	Electromagnetic compatibility – Electrical apparatus for the detection and measurement of combustible gases, toxic gases or oxygen.
----------------	---

Low Voltage Directive 2006/95/EC

EN 61010 -1:2010	Safety requirements for electrical equipment for measurement, control, and laboratory use. Part 1: General requirements.
------------------	--

Signed:

Date: 06 November 2013



Dean Kavanagh
Programme Director

15.0 Glossary of Terms

Analyser error messages	For a list of standard error codes and for more information, please refer to section '8.0 Problem Solving' of the operating manual.
Analyser warnings	There are two types of warning messages displayed; general warnings that may not necessarily affect the instrument's function, for example battery power low, and operational parameters that could affect the performance of the analyser, for example CO ₂ out of calibration.
Analyser Data Manager	Analyser Data Manager software enables the operator to maximise the operation of the instrument. Instrument readings and event log data can be downloaded to a PC for further analysis.
Area mode	'Area' is the soft-key used to begin operating in area or room monitoring mode. This mode automatically stores a rolling average N ₂ O reading every 15 minutes. G200 only.
Backlight	LED illumination of the LCD display, turns off after 30 seconds, pressing any key relights the display.
Battery charge	A full battery charge will take approximately four hours.
Calibration	The process that an instrument will undergo to enable it to measure and display the various parameters in accordance with the manufacturer's specification.
Chemical cell	Type of gas detector which can be fitted internally to the analyser at the time of manufacture.
Clean air purge	Process used to clear out gas from the inlet pipe and the analyser's gas sensors prior to taking a new reading.
CO	Carbon monoxide gas.
CO₂	Carbon dioxide gas.
Contrast adjustment	Adjustable setting which darkens or lightens the text displayed on the screen. Typically, this is used to compensate for different environmental temperatures. High temperature causes the display to darken and low temperature causes the display to lighten.
Data logging	A mode of operation that enables the user to leave the analyser unattended to take readings

automatically at predetermined times. The reading interval and pump run-time may be adjusted prior to commencing the logging cycle.

Download

Terminology used to describe the transfer of data from the analyser to a PC via Analyser Data Manager.

Event log

Record of significant events in the life of the analyser. Used as an aid to monitoring the use of the analyser. It can also be used as a diagnostic tool if there is a problem with the analyser. The event log can be viewed via Analyser Data Manager. It cannot be viewed on the analyser screen.

Exhaust port

The point at which the gas exits the analyser. This is located on the top of the analyser. It is threaded to take an M5 hose-barb to allow an exhaust tube to be attached if required.

Exhaust tube

Clear plastic tubing used to route gases from the exhaust port.

Factory settings

Default calibration settings preset at time of factory calibration.

Firmware

Firmware is the name given to the analyser's internal software. This can be programmed using the re-flash command on Analyser Data Manager. The latest software release can be downloaded from the Geotech website. It is also automatically updated when the analyser is returned for servicing.

General warnings

Displayed throughout the documentation with a warning symbol. Warning information may affect the safety of users.

Inlet port

Port located on the top of the analyser to which the inlet tube is attached.

Leak mode

'Leak' is the soft-key used to begin operating the instrument in leak detection mode. This extends the range of the N₂O sensor up to 10,000ppm and speeds up the response time to enable it to indicate the current level of N₂O. G200 only.

LCD display

Liquid Crystal Display. Fitted to the front panel of the analyser.

Main Read Screen

The main analyser screen for normal operations and all operations are carried out from this screen.

Memory

The analyser memory should not be used as a permanent storage medium and data collected should be transferred using Analyser Data

	Manager.
N₂	Nitrogen gas.
N₂O	Nitrous oxide gas.
O₂	Oxygen gas (typically 20.9% in air, measured via electro-chemical cell).
OEL	Occupational Exposure Limits.
Over range codes	Over range codes are errors above the maximum allowed reading and will be displayed with more than chevrons (>>.>).
Person mode	'Person' is the soft-key used to begin operating in personal safety monitoring mode. This mode automatically stores an average N ₂ O reading every 15 minutes. G200 only.
ppm	Parts per million.
Predetermined	Set up prior to use via Analyser Data Manager software.
Pressure	Maximum input pressure 300mb maximum flow 250ml.
Pump	The device used to transfer a gas sample into the instrument where that sample is not under pressure. Select the 'Pump' key on the analyser to activate.
Regulator flow	The regulator's flow is factory set. It only requires a few turns to open, no adjustment is available.
Sample tube	Tube used to transfer sample gas from the source to the analyser.
Soda lime CO₂ filter kit	Removes CO ₂ when taking a reading. Must be fitted on the G200 model.
Span	The point at which the gas analyser is calibrated when a known concentration of the target gas is present.
TWA	Time Weighted Average.
Under range codes	Under range codes are errors below zero and will be displayed with less than chevrons (<<.<).
User calibration	Users have the facility to calibrate the analyser between services. User calibration of the gas analyser will improve the data accuracy in the range of the calibration gases used.

Warm-up self-test

Predetermined self-test sequence to test the analyser functions which takes place after the analyser is switched on and lasts approximately 30-40 seconds.

Warranty

The instrument is guaranteed against defect in materials and workmanship for a period of 12 months from the date of shipment to the user and is subject to the recommended service and recalibration requirements.

Zero

The point at which the gas analyser is calibrated when there is none of the target gas present.